

# Miele

## Operating and installation instructions



### Frost free fridge-freezer with PerfectFresh zone and ice cube maker KFN 14947 SDE ed/cs

To avoid the risk of accidents or damage to the appliance, it is **essential** to read these instructions before it is installed and used for the first time.

en - GB

M.-Nr. 09 021 000

# Contents

---

<b>Guide to the appliance</b> .....	3
<b>Caring for the environment</b> .....	5
<b>Warning and Safety instructions</b> .....	6
<b>How to save energy</b> .....	11
<b>Before using for the first time</b> .....	12
Cleaning and care .....	12
Operating the appliance .....	12
Switching on .....	12
Switching off .....	13
To switch the refrigerator section/PerfectFresh zone or freezer section on or off separately .....	13
Switching off for longer periods of time .....	14
Settings mode .....	15
Switching the sensor tone on/off .....	15
Activating or deactivating the safety lock .....	16
<b>The correct temperature</b> .....	17
... in the refrigerator and the PerfectFresh zone .....	17
Dynamic cooling .....	17
... in the freezer section .....	17
Setting the temperature .....	18
Temperature range .....	18
Temperature display .....	19
Setting the temperature in the PerfectFresh zone .....	19
Changing the temperature display brightness .....	20
<b>Alarm</b> .....	21
Temperature alarm .....	21
Door alarm .....	22
<b>Super cool and Super freeze</b> .....	23
Super cool .....	23
Super freeze .....	24
<b>Storing food in the refrigerator</b> .....	25
Different storage zones .....	25
Food which is not suitable for storing in the refrigerator .....	26
When shopping for food .....	26
Storing food correctly .....	26
Unpacked meat and vegetables .....	26

<b>Storing food in the PerfectFresh zone</b> . . . . .	27
Storage temperature . . . . .	27
Humidity level . . . . .	27
Storing food in the PerfectFresh zone compartments . . . . .	27
<b>Adjusting the interior fittings</b> . . . . .	30
Moving the shelves . . . . .	30
Split shelf . . . . .	30
Adjusting the condiment tray/bottle shelf . . . . .	31
Universal container . . . . .	32
Moving the bottle divider . . . . .	32
<b>Freezing and storing food</b> . . . . .	33
Maximum freezing capacity . . . . .	33
Freezing fresh food . . . . .	33
Storing frozen food . . . . .	33
Home freezing . . . . .	34
Hints on home freezing . . . . .	34
Packing . . . . .	34
Before placing food in the freezer section . . . . .	35
Placing food in the freezer section . . . . .	35
Freezing large items . . . . .	35
Freezer calendar . . . . .	35
Defrosting . . . . .	36
Cooling drinks . . . . .	36
Cool pack . . . . .	36
<b>Making ice cubes</b> . . . . .	37
Setting the water intake time for the ice cube maker . . . . .	38
<b>Defrosting</b> . . . . .	40
<b>Cleaning and care</b> . . . . .	41
Cleaning the interior and accessories . . . . .	42
Appliance doors, side panels . . . . .	43
Cleaning the ice cube tray . . . . .	44
Ventilation gaps . . . . .	45
Door seal . . . . .	45
Metal grille at the back of the appliance . . . . .	45
<b>Active charcoal filters</b> . . . . .	46
To change the active charcoal filters . . . . .	46

# Contents

---

<b>Problem solving guide</b> .....	48
<b>Noises</b> .....	52
<b>After Sales / Guarantee</b> .....	53
<b>Mains water connection</b> .....	54
Notes on connecting to the mains water supply .....	54
Connection to the water inlet .....	54
<b>Electrical connection</b> .....	56
<b>Installation</b> .....	57
Location .....	57
Climate range .....	57
Ventilation .....	58
Installation .....	58
Aligning the appliance .....	58
Levelling the appliance door .....	58
Appliance dimensions .....	59
<b>Changing the door hinging</b> .....	60
<b>Aligning the appliance doors</b> .....	70
<b>Building in the appliance</b> .....	71

## Guide to the appliance

---

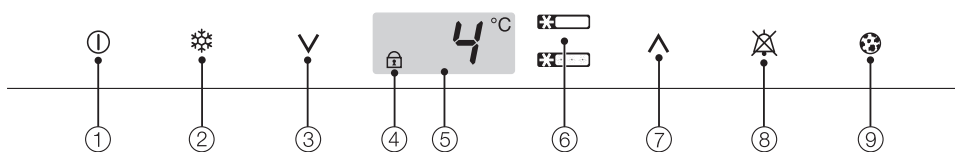

- ① On sensor for the whole appliance and On/Off sensor for switching the refrigerator and freezer sections on and off separately
- ② Super cool and Super freeze sensor
- ③ Sensor for setting a lower temperature (V)
- ④ Safety lock indicator light (only visible when the Safety lock is activated)
- ⑤ Temperature display for the refrigerator and freezer sections
- ⑥ Sensor for switching between the refrigerator and the freezer sections (top = "Refrigerator" symbol; bottom = "Freezer" symbol)
- ⑦ Sensor for setting a higher temperature (^)
- ⑧ Alarm off sensor (only visible when the door or temperature alarm sounds)
- ⑨ Change active charcoal filter indicator (only visible when the active charcoal filters need to be changed)

# Guide to the appliance

---

- ① Interior lighting
- ② Dynamic cooling fan
- ③ Adjustable shelves
- ④ PerfectFresh zone compartments
- ⑤ Control for setting the humidity in the PerfectFresh zone compartments
- ⑥ Butter and cheese compartment
- ⑦ Egg tray/Condiment tray
- ⑧ Active charcoal filter holder
- ⑨ Bottle divider
- ⑩ Bottle shelf
- ⑪ Condensate channel and drain hole
- ⑫ Ice cube drawer with automatic ice cube maker
- ⑬ Freezer drawers with freezer calendar

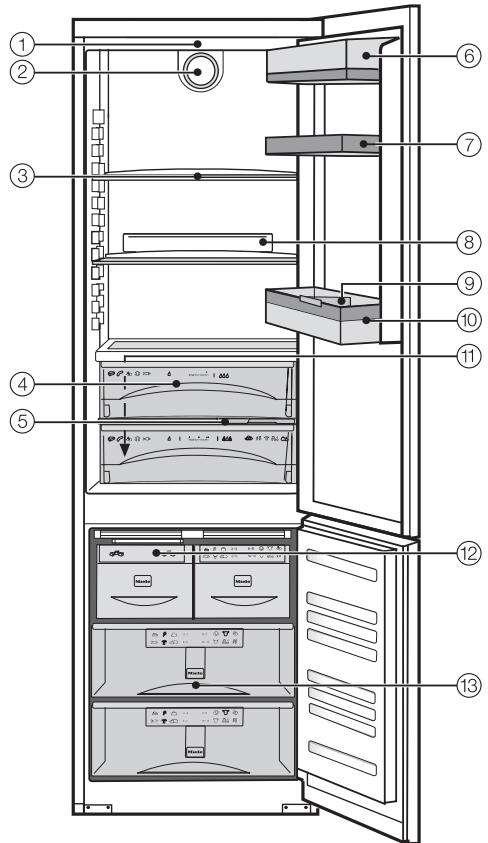

### Disposal of the packing material

The transport and protective packing has been selected from materials which are environmentally friendly for disposal, and should be recycled.

Ensure that any plastic wrappings, bags etc. are disposed of safely and kept out of the reach of babies and young children. Danger of suffocation!

### Disposal of your old appliance

Electrical and electronic appliances often contain materials which, if handled or disposed of incorrectly, could be potentially hazardous to human health and to the environment. They are, however, essential for the correct functioning of your appliance. Please do not therefore dispose of it with your household waste.

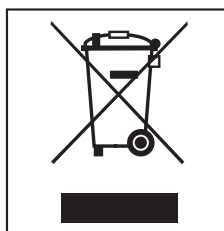

Please dispose of it at your local community waste collection / recycling centre or contact your dealer for advice. Ensure that it presents no danger to children while being stored for disposal.

Take care not to damage the pipework at the back of it before or during transportation to an authorised collection depot.

In this way, refrigerant in the pipework and oil in the compressor will be contained, and will not leak out into the environment.

# Warning and Safety instructions

---

This appliance complies with all relevant legal safety requirements. Improper use can, however, present a risk of both personal injury and material damage.

To avoid the risk of accidents and damage to the appliance, please read these instructions carefully before using it for the first time. They contain important notes on the installation, safety, operation and care of the appliance.

Keep these instructions in a safe place and pass them on to any future user.

## Correct application

► This appliance is not designed for commercial use. It is intended for use in domestic households and in similar working and residential environments such as:

- Shops
  - Offices and showrooms
- and by residents in establishments such as:
- Hostels and guest houses.

This appliance is not intended for outdoor use.

It must only be used as a domestic appliance to cool and store foodstuffs as well as to store deep frozen food, freeze fresh food and to prepare ice.

Any other usage is not supported by the manufacturer and could be dangerous. Miele cannot be held liable for damage resulting from incorrect or improper use or operation of the appliance.

► This appliance is not intended for use by persons (including children) with reduced physical, sensory or mental capabilities, or lack of experience and knowledge, unless they are supervised whilst using it, or have been shown how to use it correctly by a person responsible for their safety.

## Safety with children

► This appliance is not a toy! To avoid the risk of injury, do not allow children to play with it or near it, or to play with the controls. Neither should they be allowed to climb in drawers or swing on the doors.

Please supervise young children whilst you are using it.

Older children may only use the appliance when its operation has been clearly explained to them and they are able to use it safely, recognising the dangers of misuse.



# Warning and Safety instructions

## Technical safety

► Before setting up the appliance, check it for any externally visible damage. Do not install and use a damaged appliance.

A damaged appliance could be dangerous.

► If the connection cable is faulty it must only be replaced by a service technician authorised by the manufacturer to protect the user from danger.



**R600a**

► This appliance contains the coolant Isobutane (R600a), a natural gas which is environmentally friendly. Although it is flammable, it does not damage the ozone layer and does not increase the greenhouse effect. The use of this coolant has, however, led to a slight increase in the noise level of the appliance. In addition to the noise of the compressor, you might be able to hear the coolant flowing around the system. This is unavoidable, but does not have any adverse effect on the performance of the appliance. Care must be taken during the transportation and installation of the appliance that no parts of the cooling system are damaged. Leaking coolant can damage the eyes.

In the event of any damage:

- avoid open flames and anything which

creates a spark,

- disconnect from the mains,  
- air the room in which the appliance is located for several minutes and  
- contact the Service Department for advice.

► The more coolant there is in an appliance, the larger the room it should be installed in. In the event of a leakage, if the appliance is in a small room, there is the danger of combustible gases building up. For every 8 g of coolant at least 1 m<sup>3</sup> of room space is required. The amount of coolant in the appliance is stated on the data plate inside the appliance.

► Safe operation of the appliance is only assured if it has been installed and connected in accordance with these operating and installation instructions.

► Before connecting the appliance, make sure that the connection data on the data plate (voltage and connected load) match the mains electricity supply.

This data must correspond in order to avoid the risk of damage to the appliance. Consult a qualified electrician if in any doubt.

► Do not connect the appliance to the mains electricity supply by a multi-socket unit or an extension lead. These do not guarantee the required safety of the appliance (e.g. danger of overheating).

# Warning and Safety instructions

---

► The electrical safety of this appliance can only be guaranteed when continuity is complete between it and an effective earthing system which complies with current local and national safety regulations. It is most important that this basic safety requirement is present and tested regularly, and where there is any doubt, the household wiring system should be inspected by a qualified electrician. The manufacturer cannot be held liable for damage or injury caused by the lack of or inadequacy of an effective earthing system (e.g. electric shock).

► Installation, maintenance and repairs may only be carried out by a suitably qualified and competent person in strict accordance with current national and local safety regulations. Repairs and other work by unqualified persons could be dangerous. The manufacturer cannot be held liable for unauthorised work.

► While the appliance is under guarantee, repairs should only be undertaken by a service technician authorised by the manufacturer. Otherwise the guarantee will be invalidated.

► The appliance must be isolated from the electricity supply during installation, maintenance and repair work. The appliance is only completely isolated from the electricity supply when:

- it has been switched off at the wall socket and the plug has been withdrawn, or
- the fuse from the fused spur connection unit has been withdrawn, or
- the mains fuse has been disconnected,
- or the screw out fuse has been removed in countries where this is applicable.

► Faulty components must only be replaced by genuine Miele original spare parts. The manufacturer can only guarantee the safety of the appliance when Miele replacement parts are used.

► This appliance must not be used in a non-stationary location (e.g. on a ship).

► The manufacturer cannot be held liable for damage caused by a faulty connection to the mains water supply.

► Connection to the mains water supply and any repairs to the ice cube maker must only be carried out by a suitably qualified and competent person.

► The ice cube maker is not suitable for connection to a hot water supply.

# Warning and Safety instructions

---

▶ In countries where there are areas which may be subject to infestation by cockroaches or other vermin, pay particular attention to keeping the appliance and its surroundings in a clean condition at all times. Any damage which may be caused by cockroaches or other vermin will not be covered by the guarantee.

▶ Before making plumbing connections, ensure the appliance is disconnected from the mains electricity supply.

## Correct use

▶ Never handle frozen food with wet hands. Your hands may freeze to the frozen food or to the metal. Danger of frost burn.

▶ Do not take ice cubes out with your bare hands and never place ice cubes or ice lollies in your mouth straight from the freezer.

The very low temperature of the frozen ice or lollies can cause frost burn to the lips and tongue.

▶ Do not refreeze thawed or partially thawed food. Defrosted food should be used up as quickly as possible, as food soon loses its nutritional value and goes off. Defrosted food may only be re-frozen after it has been cooked.

▶ Do not store explosive materials in the appliance or any products containing propellants (e.g. spray cans). Thermostats switching on may produce sparks which could present a fire hazard. Flammable compounds could explode.

▶ Do not operate any electrical equipment (e.g. an electric ice-cream maker) inside the appliance. Danger of sparking and explosion.

▶ If storing alcohol with a high percentage proof in the refrigerator zone, make sure it is tightly closed and stored upright.

▶ Do not store cans or bottles containing carbonated drinks or liquids which could freeze in the freezer. The cans or bottles could explode. Danger of injury and damage to the appliance.

▶ When cooling drinks quickly in the freezer, make sure bottles are not left in for more than one hour; otherwise they could burst. Danger of injury and damage to the appliance.

▶ Observe the "use-by" dates given on food to avoid the risk of food poisoning. Storage times will depend on several factors, including the freshness and quality of the food as well as the temperature at which it is stored. Follow the instructions given on the food manufacturer's packaging regarding storage conditions and "use-by" dates.

▶ Do not use sharp edged objects to

- remove frost and ice,
- separate frozen foods and remove ice trays.

They will damage the evaporator, causing irreversible damage to the appliance.

▶ Never place electric heaters or candles in the appliance to defrost it. These can damage the plastic parts.

# Warning and Safety instructions

---

▶ Do not use defrosting sprays or de-icers, as they might contain substances which could damage the plastic parts or which could cause a build-up of gases and pose a danger to health.

▶ Do not use any oils or grease on the door seals, as these will cause the seals to deteriorate and become porous with time.

▶ If storing food which contains a lot of fat or oil, make sure that it does not come into contact with plastic components as this could cause stress cracks.

▶ Do not block the ventilation gaps in the appliance as this would impair the efficiency of the appliance, increase the electricity consumption and could cause damage to the appliance.

▶ The appliance is designed for use within certain climate ranges (ambient temperatures), and should not be used outside this range. The climate range for your appliance is stated on the data plate inside the appliance. Installing it in a room with too low an ambient temperature, e.g. a garage, can lead to the appliance switching off for longer periods so that it cannot maintain the required temperature.

▶ Do not use a steam-cleaning appliance to defrost or clean this appliance. Steam could reach the electrical components and cause a short circuit.

## Stainless steel appliances

▶ Do not use sticky notes, transparent adhesive tape, masking tape or other types of adhesive on the surface of the door.

These damage the surface, causing it to lose its dirt repellent protective coating.

▶ The high-quality surface of the door is susceptible to scratching. Even fridge magnets can cause scratching.

## Disposal of your old appliance

▶ Before disposing of an old appliance, first make the door latch or lock unusable.

This way you will prevent children from accidentally locking themselves in and endangering their lives.

▶ Be careful not to damage any part of the pipework whilst awaiting disposal, e.g. by

- puncturing the refrigerant channels in the evaporator.
- bending any pipework.
- scratching the surface coating.

Splashes of refrigerant can damage the eyes.

The manufacturer cannot be held liable for damage caused by non-compliance with these Warning and safety instructions.

# How to save energy

	<b>Normal energy consumption</b>	<b>Increased energy consumption</b>
<b>Installation site</b>	In a ventilated room.	In an enclosed, unventilated room.
	Protected from direct sunlight.	In direct sunlight.
	Not near to a heat source (radiator, oven).	Near to a heat source (radiator, oven).
	Where the ideal ambient room temperature is approx. 20°C.	Where there is a high ambient room temperature.
	Do not cover the ventilation gaps and dust them regularly.	
<b>Temperature setting with a thermostat which is approximate (set in stages).</b>	With a medium setting of 2 to 3.	With a high setting: the lower the temperature in the compartment, the higher the energy consumption.
<b>Temperature setting with a thermostat which is exact to the degree (digital display).</b>	Larder section 8 to 12 °C	On appliances with winter setting, please make sure that the winter setting is switched off when the ambient temperature is warmer than 16 °C .
	Refrigerator section 4 to 5 °C	
	PerfectFresh zone just above 0 °C	
	Freezer section -18 °C	
	Wine storage section 10 to 12 °C	
<b>Use</b>	Drawers, shelves and racks arranged as they were when the appliance was delivered.	
	Only open the door when necessary and for as short a time as possible.	Frequent opening of the door for long periods will cause a loss of coldness.
	Store food in an organised way.	Searching for an item will mean the door is open for longer.
	Allow hot food and drinks to cool down before placing them in the appliance.	Hot food will cause the refrigerator unit to run for a long time, as the appliance will have to work harder to reduce the temperature.
	Store food covered or packaged.	The evaporation or condensation of liquids will cause a loss of coldness in the refrigerator.
	Place frozen food in the refrigerator to defrost.	
	Do not over-fill the appliance to allow air to circulate.	
	<b>Defrosting</b>	Defrost the freezer section when a layer of ice 0.5 cm thick has built up.

# Before using for the first time

---

## Protective foil

The stainless steel trim to the interior shelves and the door shelves has a layer of protective foil to prevent damage during transportation. On stainless steel appliances, the outer surfaces are also covered with protective foil.

- Do not remove the foil until the appliance has been positioned in its final location.

## Cleaning and care

- Treat the stainless steel trim to the interior shelves and the door shelves with the Miele stainless steel conditioner supplied as soon as you have removed the foil.

- On stainless steel appliances also treat the side panels with the Miele stainless steel conditioning agent supplied as soon as you have removed the protective foil. The appliance doors have a special finish which is resistant to soiling. **Do not use** Miele stainless steel conditioner on the appliance door.

Important. Each time it is used, the Miele stainless steel conditioning agent forms a water and dirt repellent protective coating.

- Clean the inside of the appliance and the accessories with lukewarm water and a little washing up liquid, and then dry with a soft cloth.

## Active charcoal filters (Active AirClean filters)

- Place the active charcoal filters supplied in the holder, and place the holder on one of the refrigerator shelves (see "Active charcoal filters").

## Operating the appliance

A light touch of the finger on the sensors is all that is required to operate this appliance.

## Switching on

The refrigerator section/PefectFresh zone and freezer sections are switched on together with the On/Off sensor.



- Touch the On/Off sensor until the temperature display lights up.

The temperature display for the refrigerator section will show the current temperature in the refrigerator section.

If the temperature in the freezer section is above 0 °C, only bars will light up in the temperature display for the freezer section. As soon as the temperature is below 0 °C, the temperature display for the freezer section will show the current temperature in the freezer section.

The "Freezer" symbol and the Alarm off sensor will flash until the temperature in the freezer section has cooled down to the correct temperature for freezing.

The appliance will start to cool, and the interior lighting will come on when the refrigerator section door is opened.

# Before using for the first time

To enable the temperature to get sufficiently cold inside the appliance, allow the appliance to run for a few hours before placing food in it.

Do not place food in the freezer section until the temperature is at least  $-18^{\circ}\text{C}$ .



This sensor is used to switch between the refrigerator and freezer sections.

If you want to select the freezer section (to check the temperature, for example),



- touch the sensor for selecting the freezer/refrigerator section until the "Freezer" symbol lights up yellow.

Depending on which section you have selected, you can

- select either Super cool or Super freeze, or
- adjust the temperature.

Please refer to the relevant section for more information.

## Cool pack

Place the cool pack in the top freezer drawer. The cool pack will be at its most effective after it has been in the freezer for approx. 24 hours.

## Switching off



- Touch the On/Off sensor until all of the indicators go out. (If this does not happen, the safety lock is still activated).

The refrigerator section/PerfectFresh zone and freezer section will switch off one after the other.

The interior lighting will not come on when you open the door and the cooling process will be switched off.

## To switch the refrigerator section/PerfectFresh zone or freezer section on or off separately

The refrigerator section/PerfectFresh zone and the freezer section can be switched on or off separately, if you should only wish to use one section. This is useful, e.g. whilst on holiday, if you only want to leave the freezer section switched on:

## Before using for the first time

---



- Select the section of the appliance which you wish to switch off.

The "Refrigerator" or the "Freezer" symbol will light up yellow.



- Touch the On/Off sensor until the "Refrigerator" or the "Freezer" symbol goes out.

The section you selected is now switched off while the other section remains switched on.

### To switch a section back on again:



- Select the section which you want to switch on. The relevant symbol will light up yellow.
- Touch the On/Off sensor until the temperature display lights up, or
- Switch the appliance off and then back on again.

## Switching off for longer periods of time

If the appliance is not going to be used for a longer period of time, e.g. whilst on holiday:

- switch the appliance off,
- switch off at the wall socket and withdraw the plug,
- empty and clean the ice cube tray,
- close the stopcock for the water inlet,
- clean the appliance out and
- leave the appliance doors ajar to air the appliance.

If, during a long absence, the appliance is switched off but not cleaned out and the doors are left shut, there is a danger of mould and odours building up inside the appliance.



# Before using for the first time

## Settings mode

Certain settings on the appliance can only be selected in the settings mode.

How to select the settings mode and how to change the settings is described in the relevant section of these instructions.

Overview of functions that can be selected in the settings mode:

To enter or leave the settings mode	<i>c</i>
To switch the sensor tone on/off (see "Switching on and off")	<i>b</i>
To confirm that the active charcoal filters have been changed (see "Active charcoal filters")	<i>h</i>
To switch the safety lock on/off (see "Switching on and off")	<i>u</i>
To change the brightness of the temperature display (see "The correct temperature")	<i>d</i>
To adjust the temperature in the PerfectFresh zone (see "The correct temperature")	<i>o</i>
To set the water intake time for the ice cube maker (see "Making ice cubes")	<i>e</i>

The door alarm is automatically disabled when the appliance is in the settings mode. As soon as the door is closed, the door alarm is activated again.

## Switching the sensor tone on/off

The tone which sounds each time a sensor is touched can be deactivated.



- Touch and leave your finger on the ∇ sensor.



- At the same time, briefly touch the On/Off sensor (without letting go of the ∇ sensor).
- Leave your finger on the ∇ sensor for another 5 seconds until *c* appears in the display.
- Touch the ∇ sensor repeatedly until *b* appears in the display.
- Touch the On/Off sensor.
- By touching the ∇ sensor, you can now select whether the sensor tone is switched on or off:
  - b* 0: Sensor tone is switched off
  - b* 1: Sensor tone is switched on
  - b* -: Return to menu

## Before using for the first time

---

The old setting lights up, and your newly selected setting flashes.

- Touch the On/Off sensor to confirm the new setting.
- Touch the √ sensor repeatedly until ⌂ appears in the display.
- Touch the On/Off sensor.

You have now left the settings mode.

### Activating or deactivating the safety lock

The safety lock can be activated to prevent the appliance being switched off inadvertently.



- Touch and leave your finger on the √ sensor.



- At the same time, briefly touch the On/Off sensor (without letting go of the √ sensor).
- Leave your finger on the √ sensor for another 5 seconds until ⌂ appears in the display.
- Touch the √ sensor repeatedly until ⌂ appears in the display.
- Touch the On/Off sensor.

- By touching the √ sensor, you can now select whether the safety lock is switched on or off:
  - ⌂ √: The safety lock is deactivated
  - ⌂ √: The safety lock is activated
  - ⌂ -: Return to menu

The old setting lights up, and your newly selected setting flashes.

- Touch the On/Off sensor to confirm the new setting.
- Touch the √ sensor repeatedly until ⌂ appears in the display.
- Touch the On/Off sensor.

You have now left the settings mode.

The safety lock indicator  will light up in the temperature display when the safety lock has been activated.

# The correct temperature

---

It is very important to set the correct temperature for storing food in the appliance. Micro-organisms will cause food which is not stored at the correct temperature to deteriorate rapidly. Temperature influences the growth rate of these micro-organisms. Reducing the temperature reduces their growth rate.

The temperature in the appliance will rise:

- the more often the door is opened and the longer it is kept open,
  - the more food that is stored in it,
  - the warmer the food is which is being put into it,
  - the higher the ambient temperature surrounding the appliance.
- The appliance is designed for use in specific ambient temperatures (climate ranges). Do not use in ambient temperatures for which it is not designed.

## . . . in the refrigerator and the PerfectFresh zone

We recommend a temperature of **4 °C** in the middle of the refrigerator.

The temperature in the PerfectFresh zone is controlled automatically, and is maintained at **0 to 3 °C**.

## Dynamic cooling

The dynamic cooling fan automatically switches on when the cooling system for the refrigerator switches on. It distributes the temperature in the appliance to all areas evenly so that all the food will be chilled to about the same degree.

## . . . in the freezer section

To freeze fresh food and to store frozen food for a long time, a temperature of **-18 °C** is required. At this temperature the growth of micro-organisms is generally halted. As soon as the temperature rises above -10 °C, the micro-organisms become active in the food again so that it cannot be kept as long. For this reason, partially defrosted or defrosted food must not be re-frozen. Food may be re-frozen once it has been cooked, as the high temperatures achieved when cooking destroy most micro-organisms.

# The correct temperature

## Setting the temperature

The temperatures in the refrigerator section/PrefectFresh zone and freezer section are set independently of one another.



- Select the refrigerator or the freezer section.

The "Refrigerator" symbol or the "Freezer" symbol will light up yellow.

- You can now use the arrow sensors on either side of the temperature display to set the temperature you require.

By touching the



∨ sensor: the temperature will get colder

∧ sensor: the temperature will get warmer.

The temperature being set will flash in the display.

The following information shows in the display when the sensors are touched:

- Touching a sensor once: the **last temperature selected** flashes.
- Each subsequent touch of a sensor: adjusts the temperature shown in 1 °C steps.

- Leaving a finger on the sensor: changes the temperature continuously. When the highest or lowest temperature in the range is reached, the ∨ or ∧ sensor disappears.

Approx. 5 seconds after taking your finger off a sensor, the **average, current** temperature of the refrigerator or freezer section is automatically shown.

If you have adjusted the temperature, **wait for approx. 6 hours if the appliance is not very full and for approx. 24 hours if the appliance is full** before checking the temperature display, as it will take this long for the display to give an accurate reading. If, after this time, the temperature is still too high or too low, you will need to adjust it again.

## Temperature range

The temperature can be adjusted:

- In the refrigerator section from 3 °C to 9 °C
- In the freezer section from -14 °C to -28 °C

The ambient temperature in the room and the installation location can affect the time it takes for the appliance to reach the lowest temperature. If the ambient temperature is too high, the appliance may not reach the lowest temperature.

# The correct temperature

## Temperature display

During normal operation the temperature display on the control panel shows the temperature in the middle of the refrigerator section or the temperature in the warmest part of the freezer section.

## Setting the temperature in the PerfectFresh zone

The temperature in the PerfectFresh zone is automatically held at 0 to 3 °C. It can be raised or lowered, e.g. if you want to use it for storing items like fish.



- Touch and leave your finger on the ∇ sensor.



- At the same time, briefly touch the On/Off sensor (without letting go of the ∇ sensor).
- Leave your finger on the ∇ sensor for another 5 seconds until **c** appears in the display.
- Touch the ∇ sensor repeatedly until **a** appears in the display.
- Touch the On/Off sensor.

- You can now adjust the temperature in the PerfectFresh zone by touching the ∇ sensor. You can choose from settings **1** to **9**:
  - **1**: Lowest temperature,
  - **9**: Highest temperature.
  - **-**: Return to menu.

The old setting lights up, and your newly selected setting flashes.

- Touch the On/Off sensor to confirm a new setting.
- Touch the ∇ sensor repeatedly until **c** appears in the display.
- Touch the On/Off sensor.

You have now left the settings mode.

**a 5** is the default setting for the PerfectFresh zone. If a setting of **a 1** to **a 4** is selected, the temperature can fall below 0°C. Food could freeze!

# The correct temperature

---

## Changing the temperature display brightness

The temperature display brightness can be adjusted to suit the lighting conditions of the room.



- Touch and leave your finger on the ∇ sensor.



- At the same time, briefly touch the On/Off sensor (without letting go of the ∇ sensor).
- Leave your finger on the ∇ sensor for another 5 seconds until  $\epsilon$  appears in the display.
- Touch the ∇ sensor repeatedly until  $d$  appears in the display.
- Touch the On/Off sensor.
- The temperature display brightness can now be changed by touching the ∇ sensor:
  - $d$   $\square$ : Maximum brightness
  - $d$   $\uparrow$ : Reduced brightness
  - $d$   $-$ : Return to menu.

The old setting lights up, and your newly selected setting flashes.

- Touch the On/Off sensor to confirm a new setting.
- Touch the ∇ sensor repeatedly until  $\epsilon$  appears in the display.

- Touch the On/Off sensor.

You have now left the settings mode.

Your appliance has been fitted with a warning system which ensures that the temperature in the appliance cannot rise unnoticed and to avoid energy being wasted if a door is left open.

## Activating the alarm system

The alarm system is always active. It does not have to be switched on manually.

## Temperature alarm

An alarm will sound if the temperature becomes too warm.

The alarm off sensor will flash red and the "Freezer" symbol will flash.

The alarm will sound, the alarm off sensor will light up red and the relevant symbol will flash, for example,

- if a lot of room air enters the freezer section when food is being loaded, rearranged or taken out.
- when freezing large amounts of food at once.
- in the event of a power cut.

The alarm will stop and the indicators will go out as soon as the temperature has dropped down to the correct level again.

## Switching the temperature alarm off early

If the noise disturbs you, you can switch the alarm off early if you wish.



- Touch the alarm off sensor. The alarm will stop. The alarm off sensor will light up constantly and the relevant symbol will continue to flash until the correct temperature has been reached.

However, if the temperature in the freezer section remains above  $-18\text{ }^{\circ}\text{C}$  for a long time, check that the frozen food has not started to defrost. If it has, check that the food is safe to use and if it is, then use it as soon as possible.

# Alarm

---

## Door alarm

The alarm will sound if a door is left open for more than approx. 2 minutes.

The alarm off sensor will light up red and the symbol for the section which has the opened door will flash.

The alarm will stop and the indicators will go out as soon as the door is closed.

## Switching the door alarm off early

If the noise of the door alarm disturbs you, you can switch it off early if you wish.



- Touch the alarm off sensor.

The alarm will stop.

The alarm off sensor will light up constantly and the symbol for the section which has the opened door will continue to flash until the door has been closed.



# Super cool and Super freeze

## Super cool

The Super cool function can be used to rapidly reduce the temperature in the refrigerator to its lowest setting (depending on the room temperature).

### Switching on Super cool

Super cool is particularly recommended for the faster chilling of large amounts of fresh food or drink.

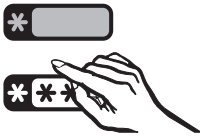

- Select the refrigerator section.

The "Refrigerator" symbol will light up yellow.



- Touch the Super cool sensor. It will light up yellow.

The appliance will then work at full power to lower the temperature in the refrigerator section.

## Switching off Super cool

The Super cool function will switch itself off automatically after approx. 6 hours. The appliance will then continue to work at normal power.

To save energy, the Super cool function can be switched off once food and drinks are sufficiently chilled.



- Select the refrigerator section.

The "Refrigerator" symbol will light up yellow.



- Touch the Super freeze sensor. It will dim to a pale yellow colour.

The appliance will continue running at normal power.

# Super cool and Super freeze

## Super freeze

Switch the Super freeze function on before putting fresh food into the freezer section.

This helps food to freeze quickly and retain its nutrients, vitamins, flavours and appearance.

### Super freeze is not necessary:

- when placing food in the freezer that is already frozen.
- when freezing up to 2 kg fresh food daily.

### Switching on Super freeze

When freezing small quantities of food in the freezer, the Super freeze function should be switched on **6 hours beforehand**. When freezing **the maximum load of food** the Super freeze function should be switched on **24 hours beforehand**.



- Select the freezer section.

The "Freezer" symbol will light up yellow.



- Touch the Super freeze sensor. It will light up yellow.  
The appliance will then work at full

power to lower the temperature in the freezer section.

### Switching off Super freeze

Depending on the amount of food placed in the freezer section, the Super freeze function will switch off automatically after approx. 30 to 65 hours. The appliance will then continue to work at normal power.

To save energy, the Super freeze function can be switched off once a constant temperature of -18 °C or colder has been reached in the freezer section.

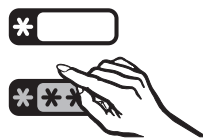

- Select the freezer section.

The "Freezer" symbol will light up yellow.



- Touch the Super freeze sensor. It will dim to a pale yellow colour.

The appliance will continue running at normal power.

# Storing food in the refrigerator

## Different storage zones

Due to the natural circulation of the air in the appliance, there are different temperature zones in the refrigerator. Cold, heavy air sinks to the lowest section of the appliance. Make use of the different zones when placing food in the appliance.

This appliance has automatic dynamic cooling, which helps to keep an even temperature when the fan is running, making the difference between the various zones less pronounced.

## Warmest area

The warmest area is in the top section of the door. Use this for storing butter and cheese.

## Coldest area

The coldest area in the refrigerator is directly above the PerfectFresh zone. However, the PerfectFresh zone is even colder.

Use these areas in the refrigerator and in the PerfectFresh zone for all delicate and highly perishable food, e.g.

- fish, meat, poultry,
- sausage products, ready meals,
- dishes or baked goods containing eggs or cream,
- fresh dough, cake mixtures, pizza or quiche dough,
- soft cheese and other dairy products,

- pre-packed vegetables and other fresh food with a label stating it should be kept at a temperature of approx. 4 °C.

Do not store explosive materials in the appliance or any products containing propellants (e.g. spray cans). Danger of explosion.

If storing alcohol with a high percentage proof, make sure it is tightly closed, and store upright.

Do not store cooking oil in the refrigerator door. Traces of oil can cause stress cracks to occur in the plastic components in the door.

Food must not touch the back wall of the refrigerator, as it may freeze to the back wall.

To allow air to circulate efficiently, do not pack food too closely together in the refrigerator. Do not cover the fan in the rear wall of the refrigerator, as this is essential for keeping the appliance cool.

# Storing food in the refrigerator

---

## Food which is not suitable for storing in the refrigerator

Not all food is suitable for storing in a refrigerator at temperatures below 5 °C, as some food is sensitive to cold. Cucumbers, for example, become glassy, aubergines bitter and potatoes sweet. Tomatoes and oranges lose their aroma, and the peel on citrus fruits hardens.

Food which is sensitive to cold includes:

- Pineapples, avocados, bananas, pomegranates, mangos, melons, papayas, passion fruit, citrus fruit (such as lemons, oranges, mandarins, grapefruit),
- Fruit which is not yet ripe
- Aubergines/egg plant, cucumbers, potatoes, peppers/capsicum, tomatoes, courgettes/zucchini,
- Some hard cheeses, e.g. Parmesan

## When shopping for food

The freshness of food when first placed in the appliance is an important factor in determining how long it stays fresh, and how long it can be kept in the refrigerator. Time out of the refrigerator, e.g. during transportation, should be kept to a minimum. For example, do not allow food to stay in a hot car for too long. Once food has started to deteriorate, this process cannot be reversed. As little as two hours outside the refrigerator can cause food to start deteriorating.

## Storing food correctly

Food should generally be stored covered or packaged in the refrigerator (there are some exceptions to this rule in the PerfectFresh zone - see below). This will prevent food smells from affecting other food, food from drying out, and also any cross-contamination of bacteria. The growth of bacteria, such as salmonella, can be avoided by setting the correct temperature and maintaining good standards of hygiene.

## Unpacked meat and vegetables

Unpackaged meat and vegetables should be stored separately. To avoid any microbiological cross-contamination, these foods may only be stored together if they are wrapped.

# Storing food in the PerfectFresh zone

Food is stored at a lower temperature in the PerfectFresh zone than in the refrigerator section. The humidity in the PerfectFresh zone compartments can also be regulated to suit the food being stored, providing ideal storage conditions and ensuring that food stays fresh considerably longer while retaining both flavour and vitamins.

## Storage temperature

The optimum storage temperature for fresh food which is not sensitive to cold is 0 - 3 °C. This is the temperature range which is automatically maintained in the PerfectFresh zone. Food can be stored there at this temperature without loss of freshness for considerably longer than in a standard refrigerator, as the deterioration process is decelerated at this temperature.

Remember that the fresher the food when placed in the appliance, the longer it will stay fresh.

## Humidity level

The humidity level in the PerfectFresh compartment will depend on

- the moisture content of the food being stored and
- the quantity of food being stored.

Use the regulator to adjust the humidity level in the PerfectFresh compartment.

The closer the storage humidity is to the humidity content of the food, the crisper and fresher the food remains over a

longer period, as the water content of the food is largely retained.

## Storing food in the PerfectFresh zone compartments

You can adjust the relative humidity in the PerfectFresh compartment with the regulator.

Slide the regulator to the relative humidity level required.

◆◆ = high humidity. The regulator closes the vents to the compartment and retains the moisture already present. The humidity level greatly depends on the type and quantity of food being stored.

Please take into account that high humidity is only achieved and effective if the food is stored **unwrapped or loosely wrapped**.

- The high humidity setting ◆◆ is ideal for storing freshly harvested produce such as vegetables, salad, herbs, cabbage and home-grown seasonal fruit.

# Storing food in the PerfectFresh zone

---

♠ = low humidity.

The regulator opens the vents to the compartment to allow the moisture to escape.

If the regulator is set at low humidity ♠, the humidity will be approx. the same as the humidity in the refrigerator section. At this setting, the low temperature is the main advantage of the compartment rather than the humidity.

- With low humidity ♠ selected, the PerfectFresh compartment is ideal for storing particularly sensitive foods, such as fresh fish, shellfish, meat, poultry, sausages, dairy products and salad.

Please note that foods rich in protein deteriorate faster than others.

Shellfish, for example, deteriorates faster than fish, and fish deteriorates faster than meat.

Always keep these foods **covered or wrapped**.

**Exception: Meat.** The surface of the meat dries out slightly, helping to prevent the growth of bacteria, which results in the meat lasting longer. To prevent the risk of bacterial cross-contamination and meat deteriorating, do not let one type of meat come into direct contact with another type.

Take food out of the PerfectFresh zone approx. 30 - 60 minutes before using it. The aroma and taste do not fully develop until the food has reached room temperature.

## Can all types of food be stored together?

Do not place all types of food together in one compartment. Some types of food do not store well together. Aromas and flavours can transfer from one type of food to another (e.g. carrots absorb the smell and flavour of onions very easily). Some food also gives off a natural gas (ethylene) which speeds up the rate at which other food perishes.

### Examples of fruit and vegetables which produce a large amount of this natural gas are:

Apples, apricots, pears, nectarines, peaches, plums, avocados, figs, blueberries, melons and beans.

### Examples of fruit and vegetables which react strongly to the natural gases given off by other types of fruit and vegetables are:

Kiwis, broccoli, cauliflower, Brussels sprouts, mangos, honeydew melons, apples, apricots, cucumbers, tomatoes, pears, nectarines and peaches.

**Example:** Broccoli should not be stored with apples, as apples produce a large amount of natural gas to which broccoli is very sensitive. The result is a shorter than expected storage time for the broccoli.

## Storing food in the PerfectFresh zone

---

**The following tips may help if you find that food you have stored does not keep well (e.g. food becomes limp or wilts after only being stored for a short time):**

- Only use the appliance for storing fresh food. The condition of the food when it is first placed in the appliance is an important factor in determining how long it stays fresh.
- Clean food before placing it in the PerfectFresh zone.
- Allow very moist food to drain before placing it in the PerfectFresh zone.
- Do not store food which is sensitive to cold in the PerfectFresh zone (see "Food which is not suitable for storing in the refrigerator")
- Bear in mind that not all types of food can be stored together (see "Can all types of food be stored together?").
- Select the correct PerfectFresh compartment (high or low humidity).
- Store food unwrapped in the high humidity PerfectFresh compartment. High humidity in the PerfectFresh compartment can only be achieved by storing food which contains moisture in it.  
If the humidity is not high enough, because, for example, too little food has been stored in the compartment, you can use a wet sponge to increase the humidity.
- If you think that the temperature in the PerfectFresh zone is too high or too low, try regulating it via the refrigerator section by altering the temperature of the refrigerator section slightly by 1 to 2 °C.  
The temperature must be increased if ice crystals start to form on the floor of the PerfectFresh zone as otherwise the cold temperature will damage the food.
- If a lot of water has gathered on the base of the PerfectFresh zone, dry the base with a towel. Drain food before storage or place a rack on the floor of the PerfectFresh zone and place the food on the rack so that the moisture can drip down.

# Adjusting the interior fittings

## Moving the shelves

The shelves can be adjusted according to the height of the food.

- Raise the shelf, and pull it forwards slightly until the notch at the side is in line with the shelf support. It can then be raised or lowered to the required level.

The raised edge at the back must face upwards to prevent food from touching the back of the appliance and freezing to it.

Stoppers prevent the shelves from being dislodged by mistake.

## Split shelf

In order to accommodate tall items in the appliance, one of the shelves is divided. The front section can be pushed under the rear section.

- Push the rear half of the glass shelf up slightly from below.
- At the same time, pull the front half of the glass shelf forwards slightly and then push it carefully under the rear half.

To move the split shelf:

- Take both halves of the split glass shelf out,

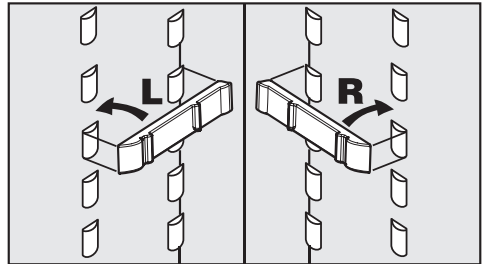

- fit the two brackets onto the supports on either side at the required height,
- and push the glass shelves in one after the other. The shelf with the raised edge must be at the back.



# Adjusting the interior fittings

## PerfectFresh zone compartments

The compartments in the PerfectFresh zone are on telescopic rails, and can be removed for filling, emptying or cleaning purposes.

- Pull out the compartment as far as it will go, and then lift it up and out.

Push the runners back in again to avoid injury or damage.

- Carefully pull out the lid between the compartments slightly, and lift it down and out.
- To replace it, insert the compartment lid from beneath into the holders, and push it back into place.

To replace the compartment,

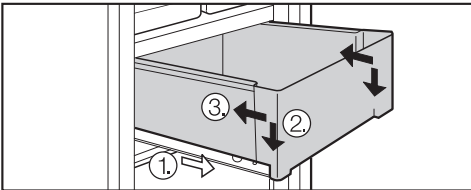

- place it back on the fully extended runners ①. The front of the runners must be right up against the front of the compartment ②.
- Then push the compartment back in ③.

## Adjusting the condiment tray/bottle shelf

- Lift the tray/shelf up and out of the stainless steel frame to remove.
- Push up the stainless steel frame, and remove.
- Replace the frame at the required height. Ensure that it is securely pushed back into position.

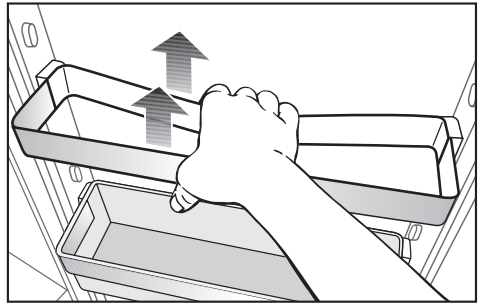

- Some stainless steel frames are easier to remove and replace if you put your hand behind the back bar of the frame and lift it upwards.
- Replace the tray/shelf in the frame.

The tray/shelf can be removed completely and used as a serving tray at the table.

# Adjusting the interior fittings

---

## Universal container

The universal container can be used both to store and serve food.

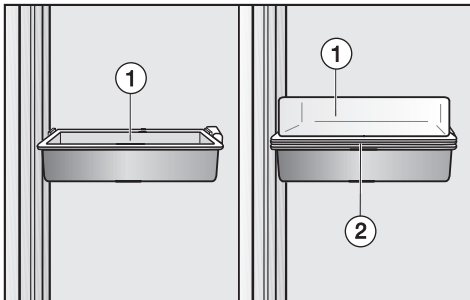

It consists of a deep tray ① and a shallow tray ②. Both trays fit the stainless steel frame.

If you wish to use the universal container to serve food,

- place the shallow tray ② in the stainless steel frame, and use the deep tray as a lid ①.

You can lift the universal container, including contents, out of the frame and take it to the table.

## Moving the bottle divider

The bottle divider can be moved to the left or right to ensure that bottles are held securely in position when the door is opened and shut.

The bottle divider can be removed completely (e.g. for cleaning).

- To do this, push up the front edge of the bottle divider, and disengage it.

## Maximum freezing capacity

To ensure that fresh food placed in the freezer freezes through to the core as quickly as possible, the maximum freezing capacity must not be exceeded. The maximum freezing capacity for freezing within a 24-hour period is given on the data plate: "Freezing capacity ....kg/24 hrs".

The maximum freezing capacity given on the data plate has been calculated according to DIN EN ISO 15502 Standard.

## Freezing fresh food

Fresh food should be frozen as quickly as possible. This way the nutritional value of the food, its vitamin content, appearance and taste are not impaired.

Food which takes a long time to freeze will lose more water from its cells, which then shrink.

During the defrosting process, only some of this water is reabsorbed by the cells; the rest collects around the food.

If food is frozen quickly, the cells have less time to lose moisture, so they shrink less. As there is not so much moisture loss, it is easier for the food to reabsorb it during the defrosting process, and very little water collects around the defrosted food.

## Storing frozen food

When buying frozen food to store in your freezer section, check

- that the packaging is not damaged,
  - the use-by date,
  - the temperature at which the frozen food is being stored in the shop. The length of time it can be kept is reduced if it has been stored at a temperature warmer than -18 °C.
- Buy frozen food once you have finished the rest of your shopping, and wrap it in newspaper or use a cool bag or cool box to transport it.
  - Store it in the freezer as soon as possible.

Never re-freeze partially or fully defrosted food. Consume defrosted food as soon as possible as it will lose its nutritional value and spoil if left for too long. Defrosted food may only be re-frozen after it has been cooked.

# Freezing and storing food

---

## Home freezing

Only freeze fresh food which is in a good condition.

### Hints on home freezing

- The following types of food **are suitable** for freezing:  
Fresh meat, poultry, game, fish, vegetables, herbs, fresh fruit, dairy products, pastry, leftovers, egg yolks, egg whites and a range of pre-cooked meals.
- The following types of food **are not suitable** for freezing:  
Grapes, lettuce, radishes, sour cream, mayonnaise, eggs in their shells, onions, whole raw apples and pears.
- To retain colour, taste and vitamin C, vegetables should be blanched after they have been trimmed and washed.  
To blanch: bring a large saucepan of water to the boil, immerse the vegetables in the fast boiling water for 2-3 minutes, depending on variety. Remove, and plunge into ice-cold water to cool quickly. Drain and pack ready for freezing.
- Lean meat freezes better than fatty meat, and can be stored for considerably longer.
- To prevent chops, steaks, cutlets or rolled meat from freezing together in solid blocks when packed, separate with a sheet of plastic freezer film.
- Do not season fresh foods or blanched vegetables before freezing. Only season cooked food

lightly before freezing, but care should be taken as the taste of some spices alters when frozen.

- Do not place hot foods or drinks in the freezer. This causes already frozen food to thaw, and increases the energy consumption considerably. Allow hot foods and drinks to cool down before placing them in the freezer.

## Packing

- Freeze food in portions.

### Unsuitable packing material

- wrapping paper
- grease-proof paper
- cellophane
- bin bags
- plastic carrier bags

### Suitable packing material

- plastic freezer film
- freezer bags
- aluminium foil
- freezer containers

- Expel as much air as possible from bags etc. before sealing them, to prevent freezer-burn on food.
- Close the packaging tightly with
  - rubber bands
  - plastic clips
  - string or bag ties
  - freezer tape.

Freezer bags may also be sealed using home heat sealing kits.

- Make a note of the contents and the date of freezing on the packaging.

# Freezing and storing food

## Before placing food in the freezer section

- When freezing more than 2 kg of fresh food, switch on the Super freeze function for some time before placing the food in the freezer (see "Super freeze").

This also helps to prevent food that is already in the freezer from starting to defrost.

## Placing food in the freezer section

Food to be frozen can be placed anywhere in the freezer.

Large quantities should be placed directly on the glass cold plates to freeze the food quickly. To do this take out the freezer drawers, leaving the bottom drawer in the appliance. The lowest freezer drawer must always remain in the appliance.

When removing the top drawers, make sure that you do not block the ventilation slits in the back wall of the appliance. They are important for trouble-free operation of the appliance.

Each drawer and each of the glass cold plates can be loaded with a maximum of 25 kg.

- Place the food flat in the bottom of the freezer drawers or on the glass cold plates so that it freezes through to the core as quickly as possible.
- Make sure that the packaging and containers are dry to prevent them sticking together when frozen.

When freezing, make sure that food already frozen does not come into contact with fresh food being frozen as this could cause the frozen food to begin to defrost.

## Freezing large items





If you wish to freeze large items such as a turkey or game, the glass cold plates between the drawers can be removed. To do this:

- Remove the freezer drawers and carefully slide out the glass cold plates.

## Freezer calendar

The freezer calendar on the freezer drawer gives the length of time in months which various foods can be stored for effectively.

Where the storage time given on the packaging differs, follow the advice on the packaging.

	2 - 3	6 - 8	
	3 - 5	10 - 12	

2-3 months:

Cakes, ice cream, stew

3-5 months:

Fish, mushrooms, bread

6-8 months:

Pork, veal, poultry

10-12 months:

Beef, fruit, vegetables

# Freezing and storing food

---

## Defrosting

Frozen food can be defrosted in different ways:

- in a microwave oven,
- in an oven using the "Fan" or "Defrost" setting,
- at room temperature,
- in the refrigerator (the cold given off by the frozen food helps to keep the other food cold),
- in a steam oven.

**Poultry** It is particularly important to observe food hygiene rules when defrosting poultry. Do not use the liquid from defrosted poultry. Pour it away and wash the container it was in, the sink and your hands. Danger of salmonella poisoning.

**Fruit** should be defrosted at room temperature in its packaging, or in a covered bowl.

**Most vegetables** can be cooked while still frozen. Just put straight into boiling water or hot fat. The cooking time is slightly less than that of fresh vegetables due to changes in the cell structure.

Never re-freeze partially or fully defrosted food. Consume defrosted food as soon as possible as it will lose its nutritional value and spoil if left for too long. Defrosted food may only be re-frozen after it has been cooked.

## Cooling drinks

To cool drinks quickly, place them in the refrigerator section, and switch on the Super cool function. If bottles are, however, placed in the freezer section for rapid cooling, make sure they are not left in for more than one hour, as they could burst.

## Cool pack

The cool pack prevents the temperature in the freezer rising too quickly in the event of a power cut.

Place the cool pack in the top drawer of the freezer section, directly on top of the food. The cool pack will be at its most effective after it has been in the freezer for approx. 24 hours.

If there is a power cut, place the cool pack directly on top of the frozen food in the top drawer so that the food will be kept cold for as long as possible.

When placing fresh food in the freezer, use the cool pack to separate the fresh food from the food which is already frozen so that the frozen food does not begin to thaw.

The cool pack can also be used in a cool bag to keep food or drinks cool for a short period of time.

For the automatic ice cube maker to operate it must be connected to the mains water supply.

## Switching on the ice cube maker

- Switch on the freezer section.

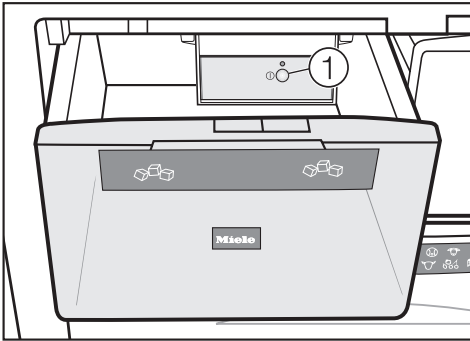

- Pull out the ice cube drawer a little way.
- Press the On/Off button ① on the ice cube maker. The indicator light will come on.
- Close the ice cube drawer.

The drawer must be completely shut for ice cubes to be produced.

After the appliance is switched on for the first time it can take up to 24 hours for the first ice cubes to drop out of the ice cube maker and collect in the drawer.

Thereafter, when the ice cube maker is switched off and then on again it will take up to a maximum of 6 hours for ice cubes to be produced.

To ensure that the water pipes are thoroughly flushed through before use, ice cubes from the first three ice cube making processes must not be consumed.

This applies not only to when the appliance is installed for the first time but also if the appliance has been out of use for a longer period (e.g. whilst on holiday).

## Making a large amount of ice cubes

The amount of ice cubes which the appliance makes depends on the temperature in the freezer section. The lower the temperature, the more ice cubes are produced within a certain time frame.

Ice cube production is halted automatically as soon as the ice cube drawer is full.

If you require a large amount of ice cubes,

- replace the full ice cube drawer with the drawer beside it on the right.

The ice cube maker will begin to produce ice cubes again as soon as this new drawer has been placed in position and closed properly.

# Making ice cubes

## Switching off the ice cube maker

The ice cube maker can be switched off independently of the freezer section if you do not want the appliance to make any ice cubes.

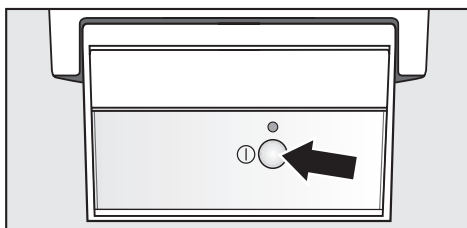

- Press the On/Off button on the ice cube maker until the indicator light goes out.

If the ice cube maker is switched off, the ice cube drawer can be used as an extra drawer for freezing fresh food and storing frozen food.

Clean the ice cube tray if the ice cube maker is going to be switched off for a long period of time.

## Setting the water intake time for the ice cube maker

The size of the ice cubes produced depends on the water pressure present and the water intake time which has been set for the ice cube maker.

If the ice cube maker is only producing small ice cubes the water pressure is low. In order to produce larger ice cubes, the water intake time for the ice cube maker needs to be prolonged.

- Switch the ice cube maker on.



- Touch and leave your finger on the V sensor.



- At the same time, briefly touch the On/Off sensor (without letting go of the V sensor).
- Leave your finger on the V sensor for another 5 seconds until  $\epsilon$  appears in the display.
- Touch the V sensor repeatedly until  $\rho$  appears in the display.
- Touch the On/Off sensor.
- Touch the V sensor repeatedly until  $\rho \rho$  appears in the display.
- Touch the On/Off sensor.



- The length of the water intake time for the ice cube maker can now be adjusted by touching the  $\vee$  sensor:  
 $E 1$ : Shortest water intake time,  
 $E 8$ : Longest water intake time,  
 $E -$ : Return to menu.

The old setting lights up, and your newly selected setting flashes.

- Touch the On/Off sensor to confirm the new setting.
- Touch the  $\vee$  sensor repeatedly until  $E -$  appears in the display.
- Touch the On/Off sensor.
- Touch the  $\vee$  sensor repeatedly until  $c$  appears in the display.
- Touch the On/Off sensor.

You have now left the settings mode.

# Defrosting

---

## Refrigerator section and PerfectFresh zone

Condensate and frost can build up on the back wall of the refrigerator section and the PerfectFresh zone whilst in use. You do not need to remove this, as it will defrost and evaporate automatically with the warmth generated by the appliance.

The condensate is drained away via a channel and drain hole into an evaporation system at the back of the appliance.

Ensure that the condensate channel and drain hole are kept clean and are never blocked so that condensate can flow away without hindrance.

## Freezer section

This appliance is equipped with a "Frost free" system. The freezer section defrosts automatically.

The moisture generated in the appliance collects on the condenser and is automatically defrosted and dissipated by the condenser from time to time.

This automatic defrosting system enables the freezer section to remain permanently ice-free, however, the food stored in the freezer section will not defrost.

A range of Miele branded cleaning and conditioning products is available to order from Miele or [www.miele-shop.com](http://www.miele-shop.com).

Make sure that no water can penetrate into the electronic unit or into the light.

Do not let water get into the drainage channel and drain hole when cleaning.

Do not use steam cleaning apparatus to clean the appliance. Steam could reach the electrical components and cause a short circuit.

The data plate located inside the appliance must not be removed. It contains information which is required in the event of a service call.

The stainless steel doors have a special finish which is resistant to soiling.

**Do not treat** the doors with stainless steel conditioning agent as this will cause noticeable smearing.

However, do use Miele stainless steel conditioning agent to treat the other stainless steel surfaces of the appliance (available from Miele or [www.miele-shop.com](http://www.miele-shop.com)).

Unlike stainless steel cleaning agents, the conditioning agent does not contain any abrasive substances and will gently remove soiling. Each time it is used, it forms a water and dirt repellent protective coating.

## **To avoid damaging the surface of your appliance, do not use:**

- cleaning agents containing soda, ammonia, acids or chlorides,
- cleaning agents containing descaling agents,
- abrasive cleaning agents, e.g. powder cleaners and cream cleaners,
- solvent-based cleaning agents,
- stainless steel cleaning agents,
- dishwasher cleaner,
- oven sprays,
- glass cleaning agents,
- hard, abrasive sponges and brushes, e.g. pot scourers,
- melamine eraser blocks,
- sharp metal scrapers.

## **Before cleaning**

- Switch the appliance off.
- Disconnect it from the mains.
- Take any food out of the appliance and store it in a cool place.
- Take out any removable parts, e.g. shelves, for cleaning.

## Cleaning and care

- The bottle shelf and condiment tray in the door can be removed from their stainless steel frames for cleaning.

To remove the stainless steel trim from the lid of the butter and cheese compartment (in the top of the door), proceed as follows:

- Take the butter and cheese compartment out of the refrigerator section.
- Open the lid of the compartment.

The stainless steel trim is a tight fit across the plastic lid and will require sufficient force to detach it.

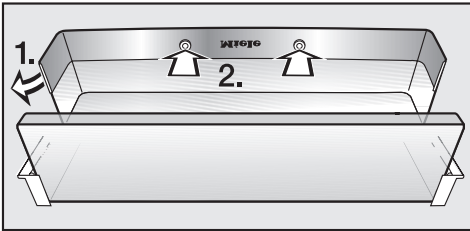

- Detach the stainless steel trim from the edge of the lid (1.) at one side and remove.
- Press the white plastic stoppers out of notches (2.).
- After cleaning, refit the stainless steel trim onto the lid in the reverse order.

## Cleaning the interior and accessories

- Clean the appliance at least once a month using lukewarm water and a little washing-up liquid.

The following are dishwasher safe:

- the butter dish, egg trays, ice cube tray (supplied as standard, depending on model)
- the bottle and condiment shelves in the door (removed from their stainless steel frames)
- the butter and cheese compartment (with the stainless steel trim removed)

The stainless steel frames and the stainless steel trim on the butter and cheese compartment in the door are **not** suitable for cleaning in a dishwasher.

The temperature of the dishwasher programme must not exceed 55 °C. Contact with some foodstuffs, such as carrots, tomatoes or ketchup can cause plastic items to discolour. However, this discolouration will not affect the stability of plastic items.

- Clean the interior shelves and drawers by hand. These are **not** suitable for cleaning in a dishwasher.
- Clean the condensate channel and drain hole frequently, so that condensate can drain away unhindered. Use a straw or similar to clear the drain if necessary.

- After cleaning, wipe the interior and accessories with a damp cloth and dry with a soft cloth.  
Leave the doors open to air the appliance for a short while.
- Miele stainless steel conditioning agent can be used to remove any soiling.
- It is important to treat the stainless steel frames and trim with Miele stainless steel conditioning agent each time they are cleaned. This will protect the surface and help prevent resoiling.

## Appliance doors, side panels

Remove any soiling on the appliance doors and side panels immediately.  
If this is not done, it might become impossible to remove and could cause the surface to alter or discolour.

All surfaces are susceptible to scratching.  
Contact with unsuitable cleaning agents can alter or discolour the surfaces.

- The surfaces should be cleaned using a solution of hot water and a little washing-up liquid applied with a soft sponge. They can also be cleaned with a damp microfibre cloth (without using any cleaning agent).
- After cleaning, wipe with a damp cloth and dry with a soft cloth.

## Stainless steel appliances

### – Appliance doors

The appliance doors have a high quality, special finish which is resistant to soiling and is very easy to clean.

**Do not use** the following to clean/condition the doors

- stainless steel cleaning agent: this will damage the surface.
- Miele stainless steel conditioning agent: this will cause noticeable smearing.

### – Side panels

- Use Miele stainless steel conditioning agent to remove any soiling from stainless steel surfaces.
- **Make sure** you treat the side panels with Miele stainless steel conditioning agent each time you clean them. This will give them a water and dirt repellent protective coating and help prevent re-soiling.

## Cleaning and care

### Cleaning the ice cube tray

Ice cubes freeze in the ice cube tray and then drop into the ice cube drawer below.

Clean the ice cube tray regularly with warm water and a little washing-up liquid to remove residual ice and water.

The ice cube tray cannot be removed and must be cleaned in situ.

You should also clean the ice cube maker before switching off the appliance for a long time (e.g. when going on holiday).

- Switch the appliance on.

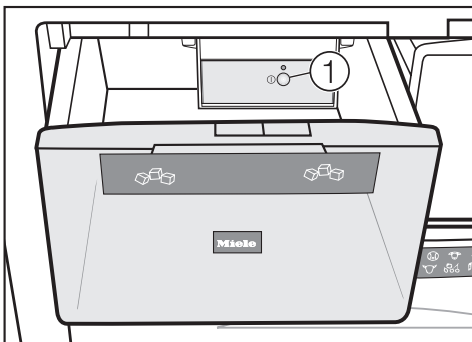

- Pull out the ice cube drawer a little way.
- Press the On/Off button ① on the ice cube maker. The indicator light will come on.
- Empty the ice cube drawer.
- Press the on/off button on the ice cube maker for at least 12 seconds.

The indicator light flashes slowly at first then quickly.

- Push the ice cube drawer in as far as it will go within the next 60 seconds.

You will hear the ice cube tray turn so that it is at an angle.

- Wait until the ice cube tray has completed this rotation before continuing.
- Then take the ice cube drawer out of the appliance and clean it.

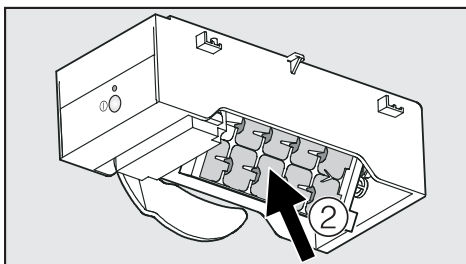

- Clean the ice cube tray ② in the ice cube maker.

After cleaning

- Press the On/Off button on the ice cube maker.
- Push the drawer all the way back into the appliance.

You will hear the ice cube tray turn back into position.

The ice cube maker will begin to produce ice cubes again after a maximum of 6 hours.

Discard the first three batches of ice cubes after cleaning. They may contain traces of washing-up liquid and are unsuitable for consumption.

If you have used a solution of water and washing-up liquid to clean it, discard the ice cubes from the first three ice cube making processes, as they are not suitable for consumption.

## Ventilation gaps

- The ventilation gaps should be cleaned regularly with a brush or vacuum cleaner. A build-up of dust will increase the energy consumption of the appliance.

## Door seal

Do not use any oils or grease on the door seals as these will cause the seals to deteriorate and become porous over time.

The door seals should be cleaned regularly with clean water, and then wiped dry with a soft cloth.

## Metal grille at the back of the appliance

The metal grille at the back of the appliance (heat exchanger) should be dusted at least once a year. A build-up of dust will increase the energy consumption of the appliance.

When cleaning the grille, make sure that the pipework and other components do not get broken or damaged in any way.

## After cleaning

- Replace all shelves and accessories in the refrigerator section.
- Place food back in the refrigerator section, close the appliance doors, insert the plug in the socket and switch the appliance on.
- Switch on the Super freeze function so that the freezer section can cool down quickly.
- Once the freezer section has reached the required temperature, place the food back in the freezer drawers and shut them.
- Switch off the Super freeze function as soon as the temperature in the freezer is a constant  $-18\text{ }^{\circ}\text{C}$  or colder.

## Active charcoal filters

The active charcoal filters should be changed approx. every 6 months.



When the Change active charcoal filter indicator lights up red, the active charcoal filters need to be changed.

### To change the active charcoal filters

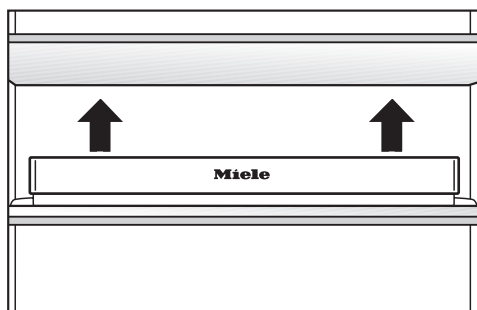

- Pull the active charcoal filter holder upwards to remove it from the shelf.

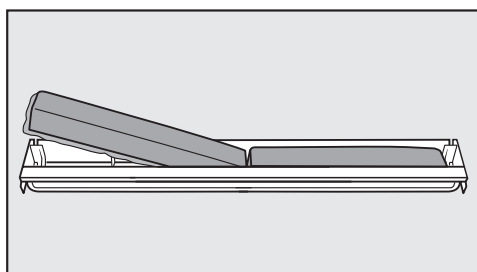

- Take out the two filters and fit the new filters into the holder with the protruding cloth edge facing downwards.
- Place the holder in the middle of the raised edge at the back of the shelf, so that it clicks into position.

To confirm the filters have been changed



- Touch the Change active charcoal filter indicator for approx. 2 seconds.

The indicator light will go out, and the counter will be reset.

### To delay changing the active charcoal filters

If you do not have new active charcoal filters, you can order them from your Miele dealer or from the Miele Spare Parts Department.

You can switch off the Change active charcoal filter indicator early, if you would prefer not to have the red indicator showing.



- Touch the Change active charcoal filter indicator for approx. 2 seconds.

The Change active charcoal filter indicator will go out.



If you have delayed changing the active charcoal filters and the indicator is not lit up, you will need to reset the counter when you replace the active charcoal filters via the settings mode.



- Touch and leave your finger on the ∇ sensor.



- At the same time, briefly touch the On/Off sensor (without letting go of the ∇ sensor).
- Leave your finger on the ∇ sensor for another 5 seconds until  $\epsilon$  appears in the display.
- Touch the ∇ sensor repeatedly until  $h$  appears in the display.
- Touch the On/Off sensor.
- Touch the ∇ sensor repeatedly until  $h 2$  appears in the display.
- Touch the On/Off sensor for approx. 2 seconds to confirm.

The counter is now reset.

- Touch the ∇ sensor repeatedly until  $\epsilon$  appears in the display.
- Touch the On/Off sensor.

You have now left the settings mode.

### Useful tip:

When you are storing foods with a strong smell (such as ripe cheeses),

- place the holder containing the active charcoal filters on the shelf where the food is going to be stored,
- change the active charcoal filters early if required (remembering to reset the counter),
- and place more active charcoal filters (in holders) in the appliance.

Active charcoal filters and holders can be obtained from your Miele dealer or from the Miele Spare Parts Department.

# Problem solving guide

---

Repairs to electrical appliances should only be carried out by a suitably qualified and competent person in strict accordance with current local and national safety regulations. Repairs and other work by unqualified persons could be dangerous. The manufacturer cannot be held liable for unauthorised work.

## What to do if . . .

### **. . . the refrigerator section or freezer section does not get cold.**

- Check whether the relevant section is switched on. The temperature display must be lit up.
- Check that the plug is correctly inserted into the socket and switched on.
- Check that the fuse is not defective and the mains fuse has not tripped. If it has there could be a fault with the household electrical wiring, the fridge-freezer or another electrical appliance. Contact a qualified electrician or Miele.
- Check the temperature settings.

### **. . . the door to the freezer section will not open because it has been opened and closed too many times in succession.**

This is not a fault. The suction caused by opening and closing the door is preventing it from opening. Wait a few minutes and then try again. It should now open without force.

### **. . . the temperature in the refrigerator section or freezer section is too low.**

- Select a warmer temperature.
- Check that the doors have been closed properly.
- Has a large amount of fresh food been put in at the same time for freezing?  
This makes the compressor run for longer, causing the temperature to fall automatically.
- Super cool has not yet switched itself off.
- Super freeze has not yet switched itself off.

### **. . . the compressor is switching in too frequently and for too long.**

- Check whether the ventilation gaps have been covered over or become dusty.
- Check whether the metal grille (heat exchanger) at the back of the appliance has become too dusty.
- The doors have been opened too frequently, or a large amount of fresh food has been put in at once for freezing.
- Check that the doors have been closed properly.

### **. . . the compressor runs continuously.**

To save energy, the compressor runs at a lower speed, but for longer, when less cooling is required.

### **... the frozen food is thawing because the freezer section is too warm.**

- Is the room temperature lower than the ambient temperature for which the appliance is designed?

If so, raise the temperature of the room.

Operating in a room which is too cold will cause the cooling system to switch off for too long, causing the freezer section to become too warm.

### **... food has frozen together.**

Use a blunt instrument, e.g. a spoon handle or plastic scraper, to prise it apart carefully.

### **... the alarm sounds and the alarm off sensor is flashing.**

One of the sections is too warm, because

- the door has been opened too frequently, or large amounts of fresh food have been placed in the appliance at once.
- the ventilation gaps are blocked.

Once the problem has been resolved and the correct temperature has been reached, the alarm indicator will go out and the alarm will stop.

### **... bars light up in the temperature displays.**

Check the temperature display about 6 hours after switching on the appliance. Only temperatures within the range the appliance can display will be shown.

### **... "\_F" appears in the temperature display.**

There is a fault. Call the Service Department.

### **... the Change active charcoal filter indicator is red.**

- Replace the active charcoal filters.

You can order replacement filters via your Miele dealer or the Miele Spare Parts Department.

### **... "nA" appears in the temperature display.**

The temperature has risen too high at some point during the last couple of days because of a power cut.

- Touch the alarm off sensor whilst "nA" is lit up in the display.

The temperature display will show the warmest temperature recorded in the freezer section during the power cut.

Depending on the temperature displayed, you should check the condition of food in the freezer. If it has defrosted or started to defrost, check that it is still safe to use and if so use it as soon as possible. Defrosted food may only be re-frozen after it has been cooked.

The warmest temperature will show in the display for about 1 minute. The display will then revert to showing the current temperature in the freezer section.

# Problem solving guide

---

## **... "dn" appears in the temperature display.**

The demonstration function is activated.

- Call the Service Department.

## **... you cannot switch the ice cube maker on.**

- Check whether the appliance is connected to the electricity supply.

## **... the ice cube maker is not producing any ice cubes.**

- Was the water inlet pipe purged of air by a qualified and competent person before the appliance was used for the first time?
- Check whether the ice cube maker is switched on.
- Check whether the freezer section is switched on.
- Check whether the water inlet is open.
- Check that the ice cube drawer has been closed properly.  
It can take up to 24 hours to produce the first ice cubes.

## **... the ice cube maker is only producing small ice cubes.**

The size of ice cubes which are produced over a certain period of time will depend on the water pressure present.

If the ice cube maker is only producing small ice cubes, the water pressure is low.

- Lengthen the water intake time for the ice cube maker (see "Making ice cubes").

## **... the indicator light on the ice cube maker flashes.**

The ice cube tray is in its cleaning position (see "Cleaning and care").

If this is not the case, then there is a fault.

- Call the Service Department.

## **... you cannot switch the appliance off.**

The safety lock has been activated.

## **... the interior lighting in the refrigerator section is not working.**

- Was the door left open for too long?  
The lighting switches itself off automatically after approx. 15 minutes if the door is left open.

If this is not the case, then the interior lighting is defective.

- Disconnect the appliance from the mains. Switch off at the wall and withdraw the plug from the socket, or disconnect the mains fuse or remove the screw-out fuse in countries where this is applicable.

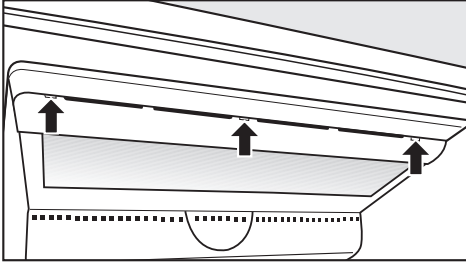

- Unclip the front cover.

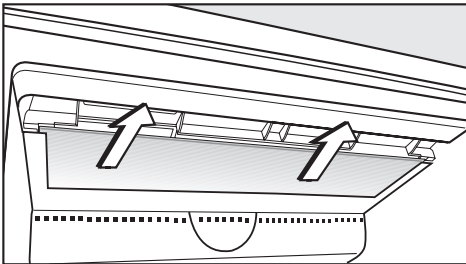

- Remove the glass panel.
- Unscrew the lamp and replace it with a new one.

Lamp specification:  
220 - 240 V, max. 25 W, E 14 fitting.

- Slide the glass panel back in again.
- Insert the cover and clip it into position.

### ... the floor of the refrigerator is wet.

The condensate drain hole is blocked.

- Clean the condensate channel and drain hole.

If you still cannot remedy the fault having followed these suggestions, please contact the Miele Service Department.

To prevent unnecessary loss of temperature it is advisable not to open the doors while waiting for the appliance to be serviced.

# Noises

Normal noises	What causes them
<b>Brrrrr...</b>	Humming noise made by the motor (compressor). This noise can get louder for brief periods when the motor is switching on.
<b>Blubb, blubb....</b>	A gurgling noise can be heard when coolant is circulating through the pipes.
<b>Click....</b>	Clicking sounds are made when the thermostat switches the motor on and off.
<b>Sssrrrrr....</b>	On multi-zone and frost-free appliances you can sometimes just hear the movement of air circulating inside the appliance.
<b>Creak ...</b>	Creaking sounds can be heard when material inside the appliance expands.

Remember that the noise of the compressor and the coolant circulating in the system is unavoidable.

Noises that you can easily rectify	What causes them, and what can you do about them
<b>Rattling, vibrating</b>	<b>The appliance is uneven:</b> Realign the appliance using a spirit level, by raising or lowering the screw feet underneath the appliance.
	<b>The appliance is touching another appliance or piece of furniture:</b> Move it away.
	<b>Drawers, baskets or shelves are unstable or sticking:</b> Check all removable items and refit them correctly.
	<b>Are any bottles or containers unstable or knocking against each other?</b> Separate them.
	<b>The transport cable clips are hanging loose at the back of the appliance:</b> Remove the clips.

In the event of a fault which you cannot correct yourself, or if the appliance is under guarantee, please contact:

– your Miele Dealer

or

– Miele  
(see back cover for contact details).

When contacting your Dealer or Miele, please quote the model and serial number of your appliance. This information is given on the data plate inside your appliance.

Please note that telephone calls may be monitored and recorded for training purposes.

N.B. A call-out charge will be applied for service visits where the problem could have been resolved as described in these instructions.

### **Guarantee**

For information on the appliance guarantee specific to your country please contact Miele. See back cover for contact details.

In the U.K. your appliance is guaranteed for 2 years from the date of delivery. However, you must activate your cover by calling 0845 365 6640 or registering online at [www.miele.co.uk](http://www.miele.co.uk).

# Mains water connection

## Notes on connecting to the mains water supply

Connection to the mains water supply should only be carried out by a qualified and competent person in accordance with national and local regulations.

The water quality must conform to the requirements for drinking water in the country the appliance is being installed in.

- This appliance complies with IEC 61770 and EN 61770 (ATS 5200.101 in Australia).
- All items used for connecting the appliance to the mains water supply must comply with the current national and local safety regulations in the country in which the appliance is being installed.
- The appliance is only suitable for connection to the cold water supply.
- The water pressure (flow rate) must be between 1.5 and 6 bar.
- The stainless steel hose is 1.5 m long. This may only be lengthened by means of a Miele extension hose. This extension hose is available from the Miele Spare Parts Department and must only be fitted by a suitably qualified fitter.
- A stopcock must be provided between the stainless steel hose and the household water supply to ensure that the water supply can be cut off if necessary.

The stopcock should be easily accessible after the appliance has been built-in.

## Connection to the water inlet

Before making plumbing connections, ensure the appliance is disconnected from the mains electricity supply.

Connection to the mains water supply should incorporate a mains stopcock with  $\frac{3}{4}$ " thread.

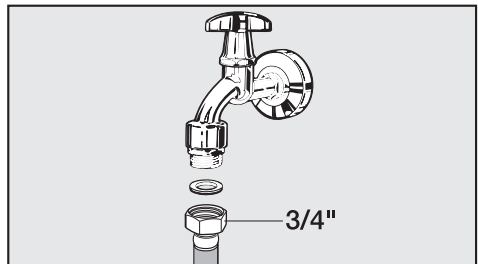

- Connect the stainless steel hose to the stopcock.
- Ensure that it is screwed into position correctly.

Before using the appliance for the first time the water inlet pipe should be purged of air by a qualified and competent person.

- To do so the stainless steel hose should be filled as far as possible with water before being connected to the solenoid valve.
- Mop up any spillages with a cloth.



## Mains water connection

---

- The stainless steel hose should be attached to the solenoid valve at the base of the appliance at the back.
- Ensure that the hose is fitted correctly and that it is water tight.
- Turn on the stopcock slowly and check the whole water system for leaks.
- The appliance can then be connected to the electricity supply.
- Push the appliance into its final position.

When doing so, make sure that the stainless steel hose is not kinked or damaged.

After a maximum of 24 hours the first ice cubes will drop out of the ice cube maker and collect in the drawer.

# Electrical connection

---

## Electrical connection U.K.

All electrical work should be carried out by a suitably qualified and competent person in strict accordance with current local and national safety regulations (BS 7671 in the UK).

The appliance is supplied with a mains cable and moulded plug ready for connection to an a.c. single phase 220-240 V 50 Hz supply.

Please ensure that the connection data quoted on the data plate match the household mains supply.

Connection should be made via a suitable switched socket which is easily accessible. For extra safety it is advisable to protect the appliance with a suitable residual current device (RCD).

Do not connect the appliance to the mains electricity supply by an extension lead. Extension leads do not guarantee the required safety of the appliance (e.g. danger of overheating).

This appliance must not be connected to the inverter of an autonomous power supply, e.g. a solar power system. When switching the appliance on, a surge in power could trigger the safety cut-out mechanism. This could damage the electronic unit.

The appliance must not be used with so-called energy saving devices. These reduce the energy supply to the appliance which could then become too warm. Using such devices could alter the specification of the product.

## Non-rewireable plugs (BS 1363)

The fuse cover must be re-fitted when changing the fuse, and if the fuse cover is lost, the plug must not be used until a suitable replacement is obtained. The colour of the correct replacement cover is that of the coloured insert in the base of the plug, or the colour that is embossed in words in the base of the plug (as applicable to the design of the plug fitted).

Replacement fuses should be ASTA approved to BS 1362 and have the correct rating. Replacement fuses and fuse covers may be purchased from your local electrical supplier.

**WARNING**  
**THIS APPLIANCE MUST BE**  
**EARTHED**

Do not place any appliance which gives off heat, such as a toaster or microwave oven, on top of this appliance, as this would increase the appliance's energy consumption.

This appliance must not be installed directly next to another refrigerator or freezer.

It does not have side-wall heating, so installation next to another refrigerator or freezer could cause a build-up of condensation between them.

Further information is available from your dealer.

## **Important: tropical / humid environments**

During periods of high humidity, some condensation may appear on outside surfaces of cooling appliances. This condensation will disappear when humidity levels drop. For prevention, it is advisable to install the appliance with sufficient ventilation in a dry and/or an air-conditioned room.

Please ensure that doors are closing and sealing properly.

Please ensure that the appliance is installed in accordance with these installation instructions and that the handle is fitted correctly. Should you require further assistance please contact your Miele customer service centre.

## **Location**

This appliance should be installed in a dry, well-ventilated room. It should not be installed where it is exposed to direct sunlight or directly adjacent to a heat-producing appliance such as an oven or a radiator. The room temperature should not go above or below the climate range for which the appliance is designed. The higher the ambient temperature of the room, the more energy the appliance requires to operate.

## **Climate range**

The appliance is designed for use within certain climate ranges (ambient temperatures), and should not be used outside this range. The climate range of the appliance is stated on the data plate inside the appliance.

<b>Climate range</b>	<b>Ambient room temperature</b>
SN	+10°C to +32°C
N	+16°C to +32°C
ST	+16°C to +38°C
T	+16°C to +43°C

Operating in a room which is too cold will result in the cooling system switching off for too long, causing the internal temperature in the appliance to rise with the risk of frozen food deteriorating and going off.

# Installation

## Ventilation

Air at the back of the appliance gets warm. To ensure sufficient ventilation, the air inlet and outlet must not be covered or blocked in any way. They should be dusted on a regular basis.

## Installation

- Remove the cable clip from the back of the appliance.
- Check that all parts at the back of the appliance are unhindered. Carefully remove any hindrance.
- Carefully push the appliance into position with the back against the wall.

## Aligning the appliance

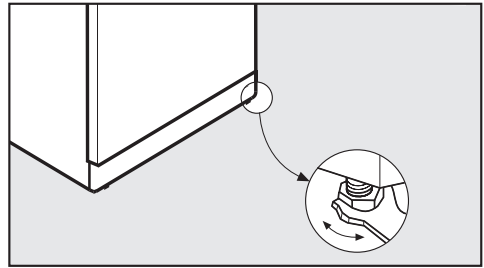

- To align the appliance, adjust the front feet using the spanner supplied.

## Levelling the appliance door

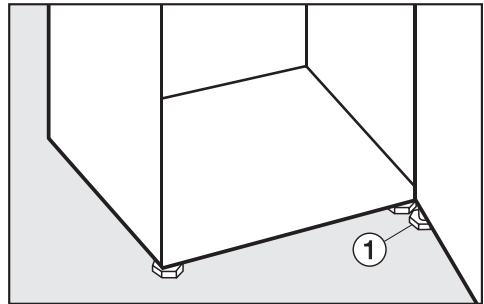

- **Ensure** that you unscrew adjusting foot ① from the hinge plate until it sits on the floor. Then unscrew the foot by a further 90°.

## Appliance dimensions

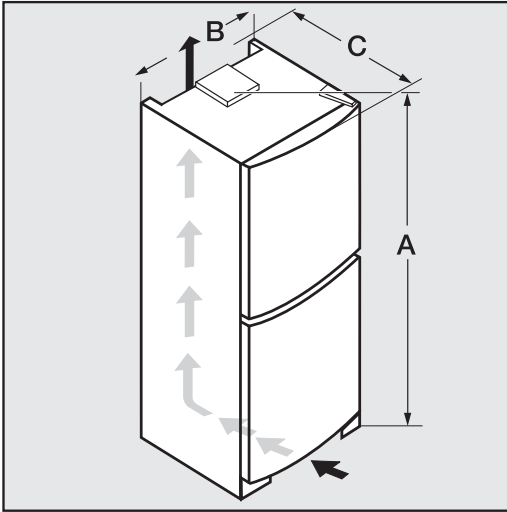

	<b>A</b>	<b>B</b>	<b>C</b>
<b>KFN 14947 SDE ed/cs</b>	2020	750	630

# Changing the door hinging

---

The appliance is supplied right-hand hinged. If left-hand door hinging is required, follow the instructions below.

**To change the door hinging you will need the following tools:**

- a cross-slotted screwdriver,
- a flat-bladed screwdriver,
- a selection of Torx screwdrivers,
- a spanner.

Two people are needed for changing the door hinging.

## Removing the door handles

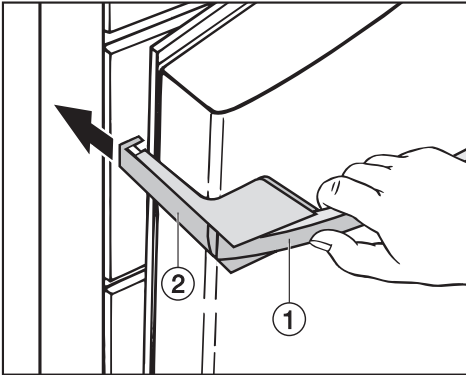

- Pull door handle ① towards you. Side section ② slides back.
- Pull side section ② firmly back out of the guides on the mounting plate.
- Undo the 4 screws (Torx 15) in the mounting plate, and remove the handle.
- Remove the cover caps from the opposite side, and fit them into the empty holes.

## Changing the door hinging

Before beginning, make sure that the door shelves are empty.

### Removing the soft-close mechanism for the upper door

- Open the upper door.

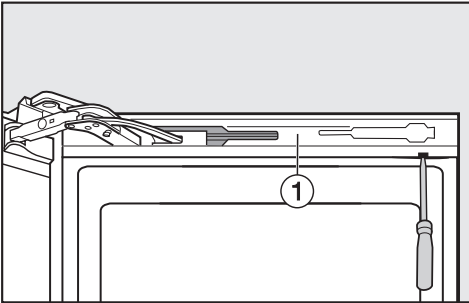

- Remove panel ① from the soft-close mechanism by inserting a flat-bladed screwdriver into the gap from above and easing it off bit by bit.

Take care not to damage the door seal.

If the door seal is damaged, the door will not close properly and cooling will be impaired.

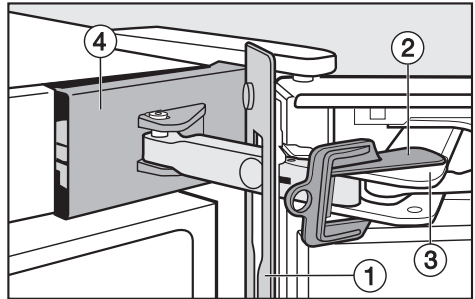

- Slide panel ① towards the appliance, and leave it hanging between the door and the appliance.
- Fit restraining clip ② (supplied with the appliance) onto soft-close mechanism ③.

The restraining clip stops the hinge from snapping shut. Do not remove the clip until told to do so.

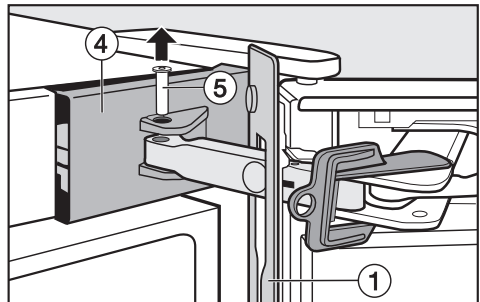

- Carefully prise open cover ④ from above and below using a flat-bladed screwdriver.
- Push hinge pin ⑤ up and out from underneath using a flat-bladed screwdriver.

# Changing the door hinging

- Remove cover ④.

The soft-close mechanism is now no longer fixed to the appliance.

- Remove panel ①.

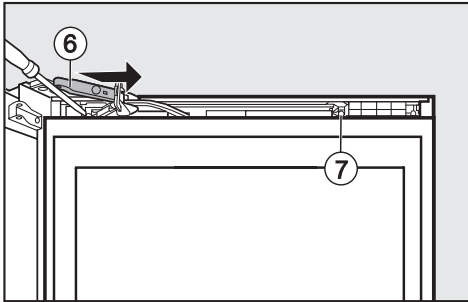

- Slide soft-close mechanism bracket ⑥ as far as it will go towards the handle side of the door.
- Undo screw ⑦ on the soft-close mechanism and the spacer.
- Using a flat-bladed screwdriver push the centre of the soft-close mechanism towards the middle of the door.
- Then prise the soft-close mechanism out of the hinge side of the door.
- Then place it to one side.
- Push the spacer out towards the hinge side.
- Then place the spacer to one side.

## Removing the upper door

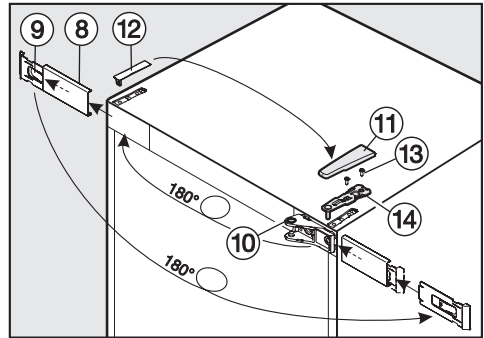

- Gently loosen cover ⑧ by carefully inserting a flat-bladed screwdriver into the gap.
- Remove cover ⑧ together with retainer plate ⑨.
- Then separate retainer plate ⑨ from cover ⑧, by pushing it slightly to the left and then pulling the cover forwards and off.
- Rotate retainer plate ⑨ by 180°.
- Then fit cover ⑧ from the front over retainer plate ⑨, and push it over to the right. The writing must be visible.
- Unscrew hinge part ⑩, rotate by 180° and fit to the opposite side. If necessary drill pilot holes for the screws.
- Remove cover ⑪ by sliding it forwards from the back and then lifting it off.
- Remove cover ⑫ by pulling it upwards.



## Changing the door hinging

Caution. The upper door is not secure as soon as the upper hinge plate is removed.

- Close the upper door.
- Undo screws ⑬ in upper hinge plate ⑭ and pull it upwards and off.
- Carefully lift the upper door off and place it to one side.
- Make sure that you leave the hinge pin in the hinge plate in the middle of the appliance, as otherwise the lower door will be unsecured.
- Then fit cover ⑧ together with retainer plate ⑨ on the opposite side.
- Refit cover ⑫ on the opposite side.

### Removing the lower soft-close door mechanism

- Open the lower door.

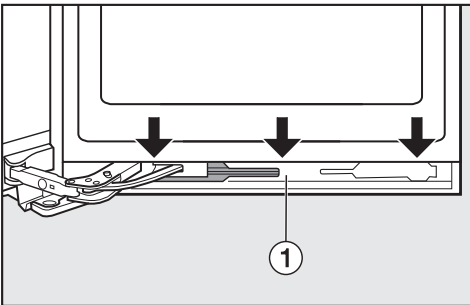

- Remove panel ① from the soft-close mechanism and ease it off carefully from above bit by bit.

Take care not to damage the door seal.

If the door seal is damaged, the door will not close properly and cooling will be impaired.

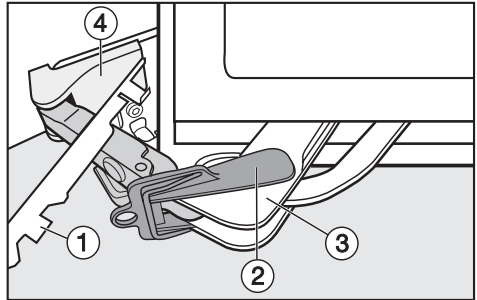

- Slide panel ① towards the appliance, and leave it hanging between the door and the appliance.
- Fit restraining clip ② (supplied with the appliance) onto soft-close mechanism ③.

The restraining clip stops the hinge from snapping shut. Do not remove the clip until told to do so.

- Carefully remove cover ④ from the side using a flat-bladed screwdriver.
- With the help of another person, tip the appliance back slightly.

# Changing the door hinging

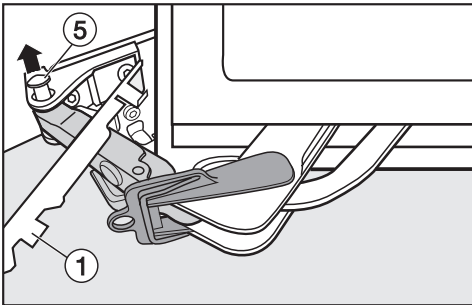

- Push hinge pin ⑤ up and out from underneath.

The soft-close mechanism is now no longer fixed to the appliance.

- Remove panel ①.

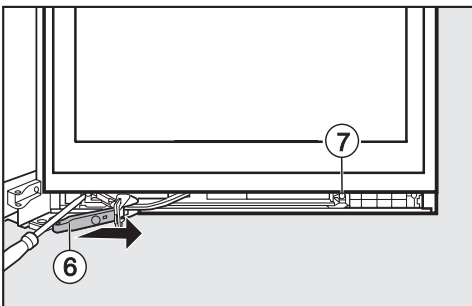

- Slide soft-close mechanism bracket ⑥ as far as it will go towards the handle side of the door.
- Undo screw ⑦ on the soft-close mechanism and the spacer.
- Using a flat-bladed screwdriver push the centre of the soft-close mechanism towards the middle of the door.
- Then prise the soft-close mechanism out of the hinge side of the door.
- Then place it to one side.
- Push the spacer out towards the hinge side.

- Then place the spacer to one side.

## Removing the lower door

- Close the lower door.

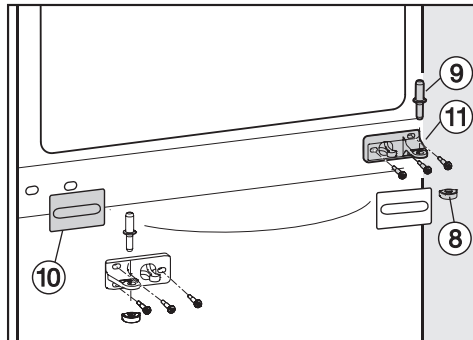

- Pull the middle hinge pin ⑨ upwards to remove it.
- Carefully lift the lower door off and place it to one side.
- Pull cover ⑩ off.
- Unscrew hinge plate ⑪, rotate it by 180° and fit it on the opposite side.
- Turn plastic cover ⑧ 180° and refit it in the centre of hinge plate ⑪.
- Refit cover ⑩ on the opposite side.

## Changing the door hinging

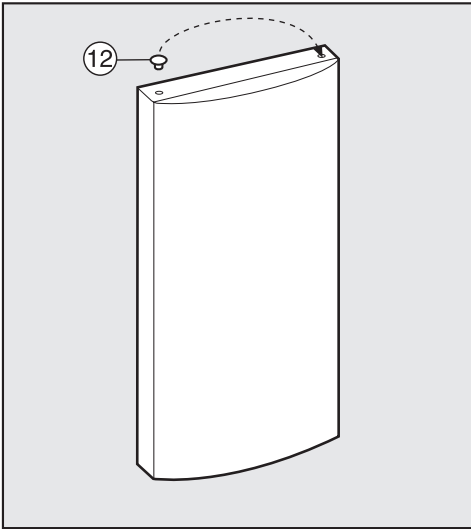

- Remove cap ⑫ from the bearing bush in the door and refit on the opposite side.

### Refitting the lower door

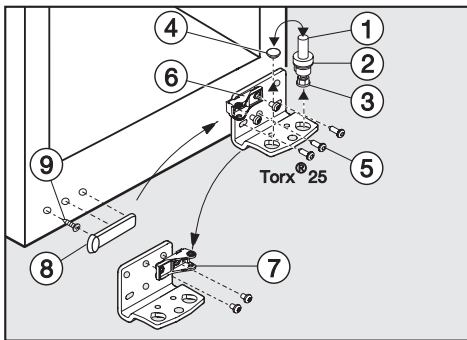

- Pull hinge pin ① together with disc ② and adjustable foot ③ upwards and off.
- Remove cover cap ④.
- Undo screws ⑤ and take hinge plate ⑥ off.

- Unscrew part ⑦ from hinge plate ⑥, rotate it by 180° and refit into the hole on the opposite side of the hinge plate.
- Refit cover cap ④ in the other hole.
- Remove cover ⑧.
- Unscrew and refit screw ⑨ into the outer hole on the opposite side.
- Turn cover ⑧ through 180°, and fit it into the holes on the other side.
- Screw hinge plate ⑥ into position on the opposite side using the two **outer** long slots only. To make it possible to align the door later, do not replace the **centre** screw at this stage.
- Important. Screw the adjustable foot ③ into hinge pin ① as far as it will go.
- Refit hinge pin ① together with disc ② and adjustable foot ③. Important. The notch at the bottom of the hinge pin should face towards the back.
- Place the lower door onto hinge pin ①.
- Close the lower door.

## Changing the door hinging

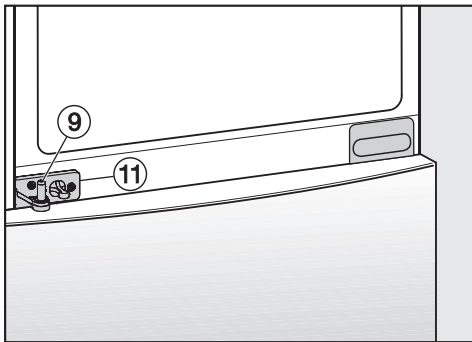

- Fit hinge pin ⑨ into middle hinge plate ⑪ in the lower door.

### Replacing the lower soft-close door mechanism

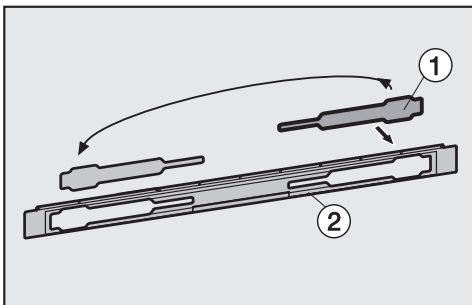

- Remove cover ① from panel ②, rotate it by 180° and refit it on the other side.

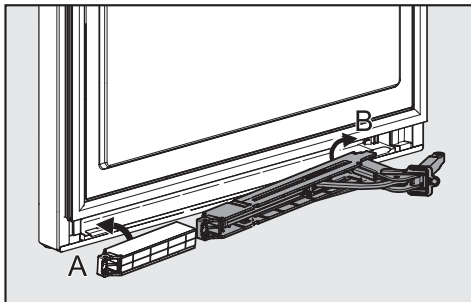

- Clip the spacer into position on the handle side (A).
- Then clip the soft-close mechanism into position on the hinge side (B).

Then push both parts from the middle until they click firmly into position.

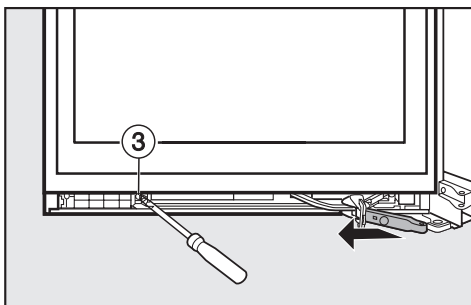

- Screw the spacer and the soft-close mechanism together securely using screw ③.

## Changing the door hinging

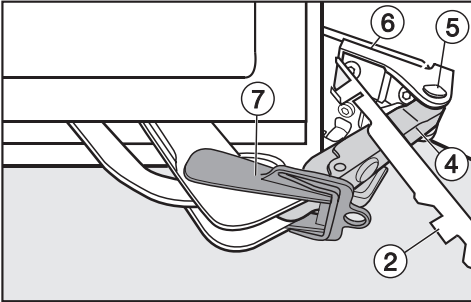

- Attach panel ② to soft-close mechanism bracket ④.
- Align bracket ④ to the hinge plate, and insert pin ⑤ from above so that the right angle fits into the recess.
- Click cover ⑥ back into place.

Make sure that cover ⑥ fits properly so that the door can be closed without hindrance and the pin is protected.

- Remove retaining clip ⑦.

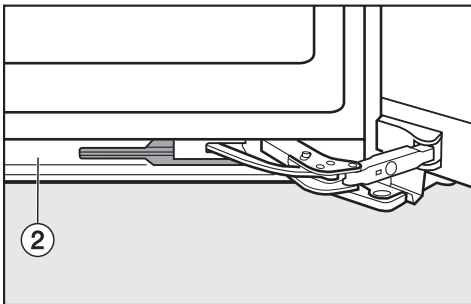

- Replace panel ② onto the soft-close mechanism from above, clicking it back into place first at the bottom and then at the top.
- Close the lower door.

### Refitting the upper door

- Then fit the upper door on middle hinge pin ⑨.
- Close the upper door.

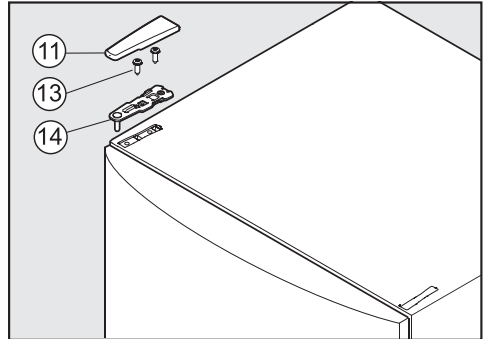

- Fit hinge plate ⑭ onto the opposite side and secure it with screws ⑬. If necessary drill pilot holes for the screws or use a battery operated screwdriver.
- Refit cover ⑪ on the opposite side.
- Align the door with the appliance housing using the long slots in the lower hinge plate. Then tighten the screws.

# Changing the door hinging

## Replacing the upper soft-close door mechanism

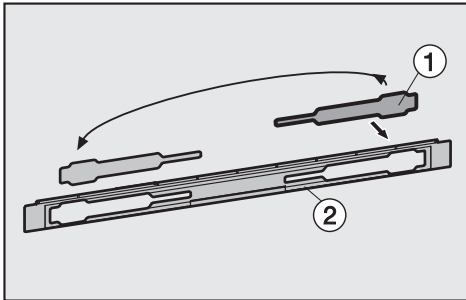

- Remove cover ① from panel ②, rotate it by 180° and refit it on the other side.

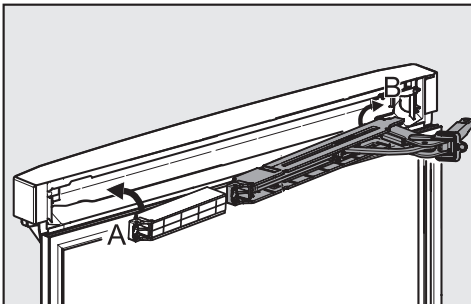

- Clip the spacer into position on the handle side (A).
- Then clip the soft-close mechanism into position on the hinge side (B).

Then push both parts from the middle until they click firmly into position.

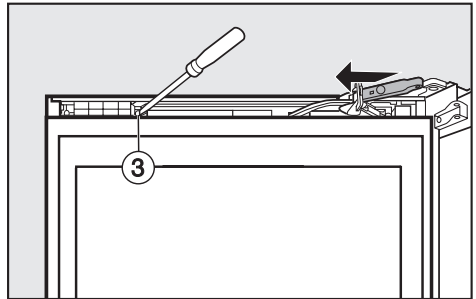

- Screw the spacer and the soft-close mechanism together securely using screw ③.

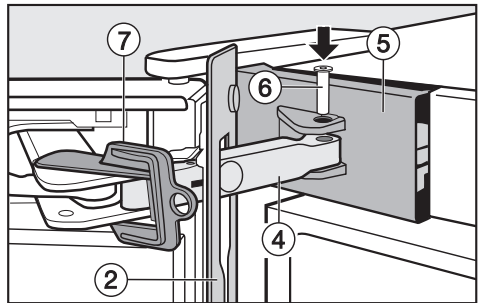

- Attach panel ② to soft-close mechanism bracket ④.
- Push cover ⑤ on from the side so that the openings for the pin ⑥ are vertically aligned.
- Align bracket ④ to the hinge plate, and insert pin ⑥ from above so that the right angle fits into the recess.
- Clip cover ⑤ into position.

Make sure that cover ⑤ fits properly so that the door can be closed without hindrance and the pin is protected.

## Changing the door hinging

- Remove retaining clip ⑦.

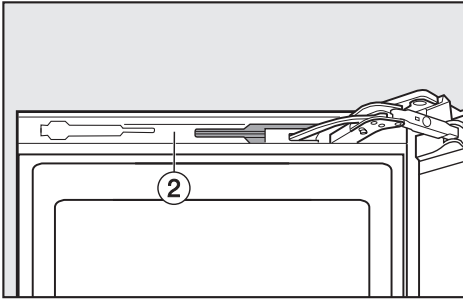

- Replace panel ② onto the soft-close mechanism from above, clicking it back into place first at the bottom and then at the top.
- Close the upper door.

### Refitting the handles

Please make sure you follow the instructions below carefully when you refit the handles. The door seal will be damaged if the handle is fitted incorrectly.

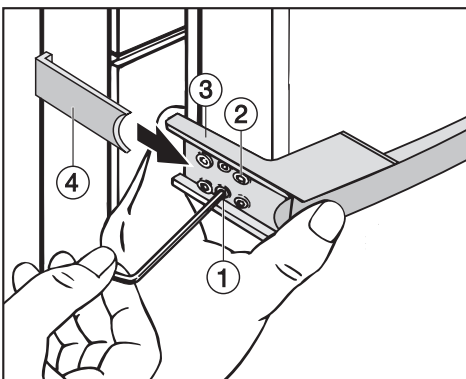

- Loosely attach the handle to the opposite side of the door with the two front screws ②.

Mounting plate ③ must be positioned on the side of the door so that when the door is **closed** it is flush with the side of the appliance.

If this is not the case,

- tighten both grub screws ① with a suitable allen key until mounting plate ③ lines up correctly.
- Then tighten all 4 screws ②.
- Slide the side section of the handle ④ into the guides on the mounting plate until it clicks into place.

It is important to check that the side section of the handle ④ does not come into contact with the door seal when opening the door, as this would damage the door seal permanently.

If, after you have refitted the handle, you find that the side section does touch the door seal when the door is opened:

- Realign mounting plate ③ with grub screws ① until the mounting plate and the side section of the handle ④ are at the correct angle and the side section does not touch the door seal when the door is opened.

## Aligning the appliance doors

The appliance doors can be aligned with the housing after they have been fitted.

In the following illustration the door is not shown in the closed position to make it easier to see what you have to do.

To align the **lower door** use the long outer slots in the lower hinge plate:

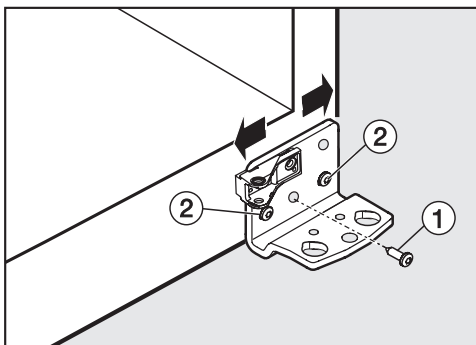

- Remove centre screw ① from the hinge plate.
- Slightly loosen both outer screws ②.
- Align the door by sliding the hinge plate to the left or right.
- Then tighten screws ② again. Screw ① does not need to be used again.

To align the **upper door** use the long outer slots in the middle hinge plate:

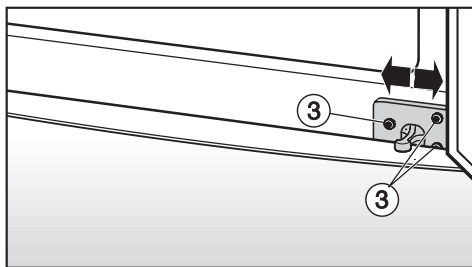

- Slightly loosen the three screws ③.
- Align the door by sliding the hinge plate to the left or right.
- Then tighten screws ③.



## Building in the appliance

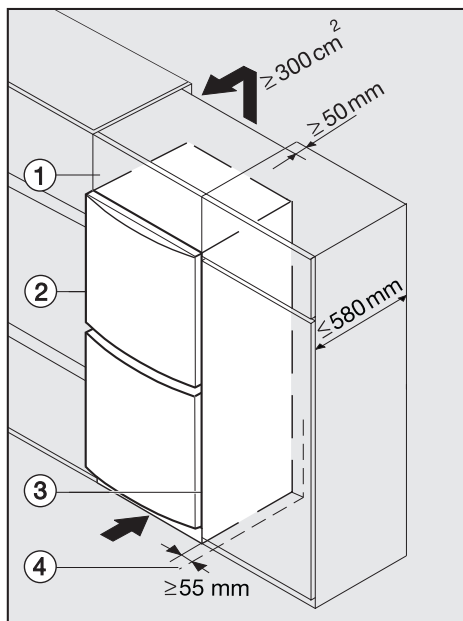

The air inlet and outlet must not be covered or blocked in any way. They should be dusted on a regular basis.

When built into a kitchen run (max. depth 580 mm) the appliance can be installed directly next to a kitchen furniture housing unit. The appliance door will protrude in front of furniture fronts at the sides by 34 mm and by 55 mm in the middle of the door. This enables the doors to be opened and shut without being obstructed.

When installed **next to a wall** (4) a distance of approx. 55 mm must be maintained on the hinge side between the wall (4) and the appliance (2), so that the doors and the handles have sufficient space for opening.

- ① Top box
- ② Appliance
- ③ Housing unit
- ④ Wall

The appliance can be installed in a kitchen run. To match the height of the rest of the kitchen, the appliance can be fitted with a suitable top box (1).

A ventilation gap of at least 50 mm depth must be allowed for behind the appliance across the entire width of the top box for air to circulate.

The cross section of the air outlet under the room ceiling must be at least 300 cm<sup>2</sup> to ensure that air can circulate without hindrance. Otherwise the appliance has to work harder, resulting in an increase in electricity consumption.





## United Kingdom

Miele Co. Ltd.

Fairacres, Marcham Road

Abingdon, Oxon, OX14 1TW

Tel: 0845 365 0555

Fax: 0845 365 0777

Customer Contact Centre Tel: 0845 365 6600

E-mail: [info@miele.co.uk](mailto:info@miele.co.uk)

Internet: [www.miele.co.uk](http://www.miele.co.uk)

## Australia

Miele Australia Pty. Ltd.

ABN 96 005 635 398

1 Gilbert Park Drive, Knoxfield, VIC 3180

Tel: (03) 9764 7130, Fax: (03) 9764 7149

Internet: [www.miele.com.au](http://www.miele.com.au)

## China

Miele (Shanghai) Trading Ltd.

1-3 Floor, No. 82 Shi Men Yi Road

Jing' an District

200040 Shanghai, PRC

Tel: +86 21 6157 3500

Fax: +86 21 6157 3511

E-mail: [mieleshanghai@cn.miele.com](mailto:mieleshanghai@cn.miele.com)

Internet: [www.miele.cn](http://www.miele.cn)

## Miele (Hong Kong) Limited

41/F - 4101, Manhattan Place

23 Wang Tai Road

Kowloon Bay

Hong Kong

Tel: (852) 2610 1331

Fax: (852) 2610 1013

Email: [mielehk@miele.com.hk](mailto:mielehk@miele.com.hk)

## India

Miele India Pvt. Ltd.

Ground Floor, Copia Corporate Suites

Plot No. 9, Jasola

New Delhi - 110025

Tel: 011-46 900 000, Fax: 011-46 900 001

E-mail: [customercare@miele.in](mailto:customercare@miele.in)

Internet: [www.miele.in](http://www.miele.in)

**Manufacturer:** Germany - Miele & Cie. KG

Carl-Miele-Straße 29, 33332 Gütersloh

# Miele

## Ireland

Miele Ireland Ltd.

2024 Bianconi Avenue

Citywest Business Campus, Dublin 24

Tel: (01) 461 07 10, Fax: (01) 461 07 97

E-Mail: [info@miele.ie](mailto:info@miele.ie), Internet: [www.miele.ie](http://www.miele.ie)

## New Zealand

Miele New Zealand Limited

Unit L, 10-20 Sylvia Park Road

Mt. Wellington, 1060, Auckland, NZ

Internet: [www.miele.co.nz](http://www.miele.co.nz)

## Singapore

Miele Southeast Asia

Miele Pte. Ltd.

163 Penang Road

# 04 - 02/03 Winsland House II

Singapore 238463

Tel: +65 6735 1191, Fax: +65 6735 1161

E-Mail: [infosea@miele.com.sg](mailto:infosea@miele.com.sg)

Internet: [www.miele.sg](http://www.miele.sg)

## South Africa

Miele (Pty) Ltd

63 Peter Place, Bryanston 2194

P.O. Box 69434, Bryanston 2021

Tel: +27 (0) 11 548-1900

Fax: +27 (0) 11 548-1935

E-mail: [info@miele.co.za](mailto:info@miele.co.za)

Internet: [www.miele.co.za](http://www.miele.co.za)

## United Arab Emirates

Miele Appliances Ltd.

P.O. Box 11 47 82

Gold & Diamond Park

Sheikh Zayed Road

Building 6 / Offices Nos. 6-214 to 6-220

Dubai

Tel: +971-4-341 84 44

Fax: +971-4-341 88 52

E-Mail: [info@miele.ae](mailto:info@miele.ae)

Internet: [www.miele.ae](http://www.miele.ae)